



BITZER Output data

Created on : 06.01.2020 14:36:58



Table of content

Project survey.....	3
Selection: Condensing Units.....	4
Technical Data: LH114E/4PES-12Y.....	5
Information: Condensing Units.....	6



Project survey

Selected compressors

Condensing Units

1x LH114E/4PES-12Y



Selection: Condensing Units

Input Values

Unit type	LH114E/4PES-12Y	Useful superheat	100%
Series	Standard	Operating mode	Auto
Refrigerant	R449A	Power supply	400V-3-50Hz
Reference temperature	Dew point temp.	Capacity control	100%
Suction gas temperature	20,00 °C		

Result

Q [W]	Cooling capacity	Op.	Operating mode
P [kW]	Power input	tc [°C]	Condensing SDT
I [A]	Current	dtau [K]	subcooling
m [kg/h]	Mass flow		

tamb	to	10°C	5°C	0°C	-5°C	-10°C	-15°C	-20°C	-25°C
27°C	Q [W]	--	--	--	27846	23257	19082	15343	12049
	P [kW]	--	--	--	11,05	9,86	8,71	7,61	6,55
	I [A]	--	--	--	17,78	16,01	14,34	12,76	11,32
	m [kg/h]	--	--	--	639	513	407	318	244
	Op.	--	--	--	Standard	Standard	Standard	Standard	Standard
	tc [°C]	--	--	--	47,8	45,0	42,4	40,0	37,9
	dtau [K]	--	--	--	3,00	3,00	3,00	3,00	3,00
32°C	Q [W]	--	--	--	25724	21426	17515	14013	10930
	P [kW]	--	--	--	11,40	10,13	8,91	7,72	6,59
	I [A]	--	--	--	18,30	16,42	14,62	12,92	11,36
	m [kg/h]	--	--	--	618	494	390	303	231
	Op.	--	--	--	Standard	Standard	Standard	Standard	Standard
	tc [°C]	--	--	--	51,9	49,2	46,7	44,4	42,3
	dtau [K]	--	--	--	3,00	3,00	3,00	3,00	3,00
43°C	Q [W]	--	--	--	--	17421	14101	11127	8514
	P [kW]	--	--	--	--	10,53	9,14	7,78	6,47
	I [A]	--	--	--	--	17,02	14,96	13,00	11,21
	m [kg/h]	--	--	--	--	450	350	268	199,2
	Op.	--	--	--	--	Standard	Standard	Standard	Standard
	tc [°C]	--	--	--	--	58,3	56,1	54,0	52,1
	dtau [K]	--	--	--	--	3,00	3,00	3,00	3,00

-- No calculation possible (see message in single point selection)
 Power input compressor, power input fan see "T. Data"

Application Limits 1 LH114E/4PES-12

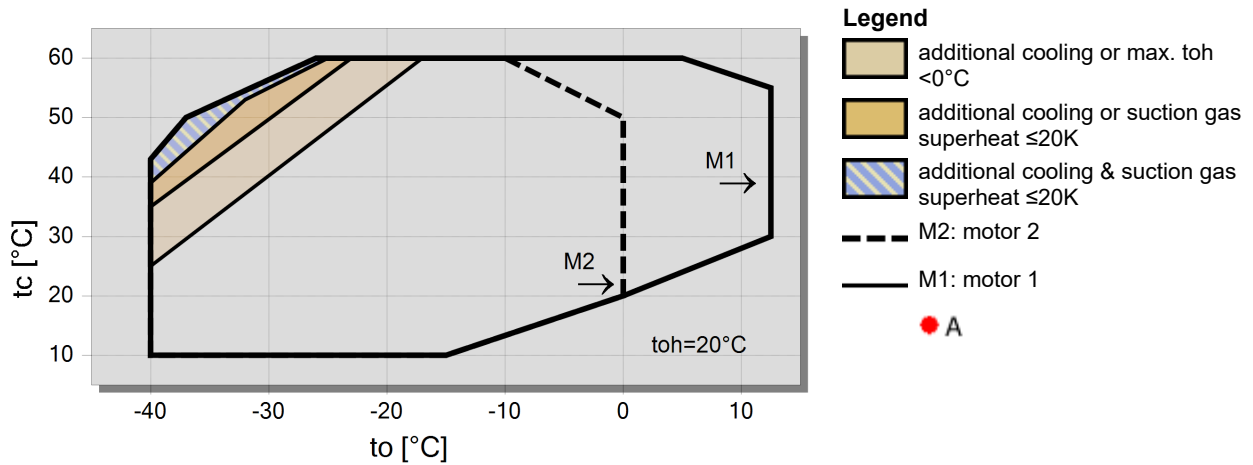



Technical Data: LH114E/4PES-12Y

Dimensions and Connections

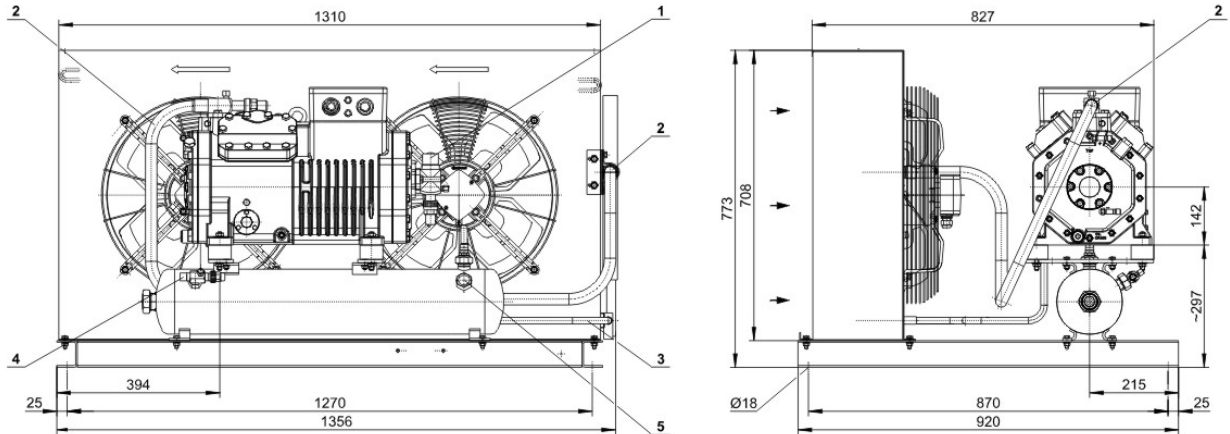

Technical Data

Technical Data

Weight	249 kg
Total width	1356 mm
Total depth	920 mm
Total height	773 mm
Connection suction line	35 mm - 1 3/8"
Connection liquid line	16 mm - 5/8"
Fans: Number	2xEC
Voltage (50Hz, more on request)	230V-1-50Hz (Standard)
Current / Power consumption of each fan (50Hz)	1,5 A / 330 W
Air flow condenser 50Hz	9300 m ³ /h
Voltage (60Hz, more on request)	230V-1-60Hz (Standard)
Current / Power consumption of each fan (60Hz)	1,8 A / 330 W
Air flow condenser 60Hz	9300 m ³ /h
Coil Volume	2,17 dm ³
Receiver type (Standard)	F152H
Max. refrigerant charge 90% at 20°C / 68°F	
R22	16,3 kg
R134a	16,5 kg
R407C	15,6 kg
R404A/R507A	14,4 kg
R407A	15,8 kg
R407F	15,4 kg
R448A	15 kg
R449A	15,1 kg
R450A	16,1 kg
R513A	16,5 kg
R1234yf	15 kg
R1234ze	15,9 kg
Receiver type (Option)	F302H
R22	32,7 kg
R134a	33,1 kg
R407C	31,3 kg
R404A/R507A	28,8 kg

Extent of delivery (Standard)

Discharge line	Standard
Protective charge	Standard

Available Options

Oil separator	Option
Check valve	Option
High & low pressure switch	Option
Dressed unit	Option
Weather protective housing	Option
Fans: elect. Speed control	Option

Sound measurement

Data of compressors: see compressor program



Condensing Units

Motor 1 = e.g. LH..E/4TES-12 with 12 "HP", primary for air-conditioning (e.g. R22,R407C) and medium temperature application (e.g. R134a, R407F, R407A, R404A, R507A, R22) and air-conditioning with R134a at high ambient temperatures.

Motor 2 = e.g. LH..E/4TES-9 with 8 "HP", for medium and low temperature application (e.g. R134a, R407F, R407A, R404A, R507A, R22) and air-conditioning with R134a.

For more information concerning the application range use the "limits" button.

Operation modes for LH..E/4VES-7 to LH../6HE-28 with R22

CIC = liquid injection with low temperature application, suction gas cooled motor

Specifications for sound emission Ecostar

The data are based on 50 Hz operation with R404A.

Soundpressure: Data are valid for free field conditions according to EN13487 with a block-shaped reference area in a distance of 10m.

For further informations see technical information for sound data.

Legend of connection positions according to "Dimensions":

- 1 Suction gas valve
- 2 Discharge gas line
- 3 Condensate line
- 4 Refrigerant outlet (liquid line)
- 5 Pressure relief valve connection
- 6 Liquid injection (operation without liquid subcooler and with thermostatic expansion valve)
- 7 Refrigerant inlet at liquid subcooler
- 8 Refrigerant outlet at liquid subcooler
- 9 Suction gas line
- 10 Sight glass
- 11 Load suspension points
- 12 Plug for screwed cable gland
- 13 Cable bushing (for cables \varnothing 9-17 mm) (only ECOLITE)

Dimensions can show tolerances according to EN ISO 13920-B.