



**BITZER Output data**

Created on : 06.01.2020 13:53:24



## Table of content

Project survey.....	3
Selection: Condensing Units.....	4
Technical Data: LH64E/2CES-3Y.....	5
Information: Condensing Units.....	6



## Project survey

### ***Selected compressors***

Condensing Units

1x LH64E/2CES-3Y



### Selection: Condensing Units

#### Input Values

Unit type	LH64E/2CES-3Y	Useful superheat	100%
Series	Standard	Operating mode	Auto
Refrigerant	R449A	Power supply	400V-3-50Hz
Reference temperature	Dew point temp.	Capacity control	100%
Suction gas temperature	20,00 °C		

#### Result

Q [W]	Cooling capacity	Op.	Operating mode
P [kW]	Power input	tc [°C]	Condensing SDT
I [A]	Current	dtau [K]	subcooling
m [kg/h]	Mass flow		

tamb	to	10°C	5°C	0°C	-5°C	-10°C	-15°C	-20°C	-25°C
27°C	Q [W]	--	--	11969	10151	8492	6999	5670	4503
	P [kW]	--	--	4,66	4,21	3,79	3,39	3,00	2,64
	I [A]	--	--	7,54	6,89	6,29	5,75	5,26	4,81
	m [kg/h]	--	--	278	227	183,6	147,0	116,2	90,4
	Op.	--	--	Standard	Standard	Standard	Standard	Standard	Standard
	tc [°C]	--	--	48,2	45,5	43,0	40,8	38,8	37,0
	dtau [K]	--	--	3,00	3,00	3,00	3,00	3,00	3,00
32°C	Q [W]	--	--	--	9466	7903	6495	5243	4144
	P [kW]	--	--	--	4,40	3,94	3,50	3,09	2,70
	I [A]	--	--	--	7,15	6,50	5,91	5,37	4,88
	m [kg/h]	--	--	--	222	178,9	142,7	112,3	86,8
	Op.	--	--	--	Standard	Standard	Standard	Standard	Standard
	tc [°C]	--	--	--	49,8	47,4	45,3	43,4	41,7
	dtau [K]	--	--	--	3,00	3,00	3,00	3,00	3,00
43°C	Q [W]	--	--	--	--	6609	5396	4318	3373
	P [kW]	--	--	--	--	4,21	3,71	3,23	2,79
	I [A]	--	--	--	--	6,89	6,19	5,55	4,98
	m [kg/h]	--	--	--	--	168,0	132,6	103,2	78,7
	Op.	--	--	--	--	Standard	Standard	Standard	Standard
	tc [°C]	--	--	--	--	57,2	55,2	53,4	51,8
	dtau [K]	--	--	--	--	3,00	3,00	3,00	3,00

-- No calculation possible (see message in single point selection)  
 Power input compressor, power input fan see "T. Data"

### Application Limits 1 LH64E/2CES-3

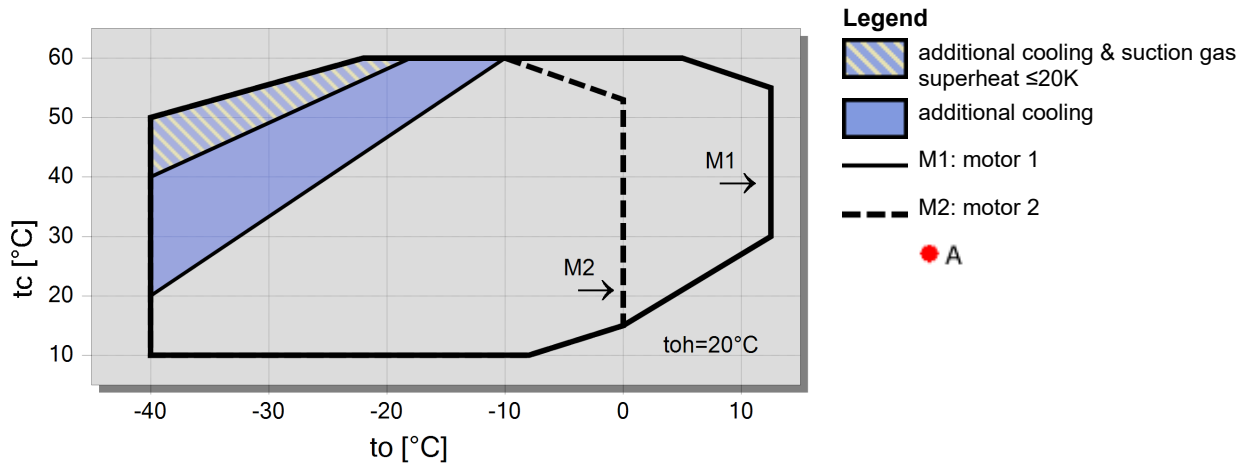



## Technical Data: LH64E/2CES-3Y

### Dimensions and Connections

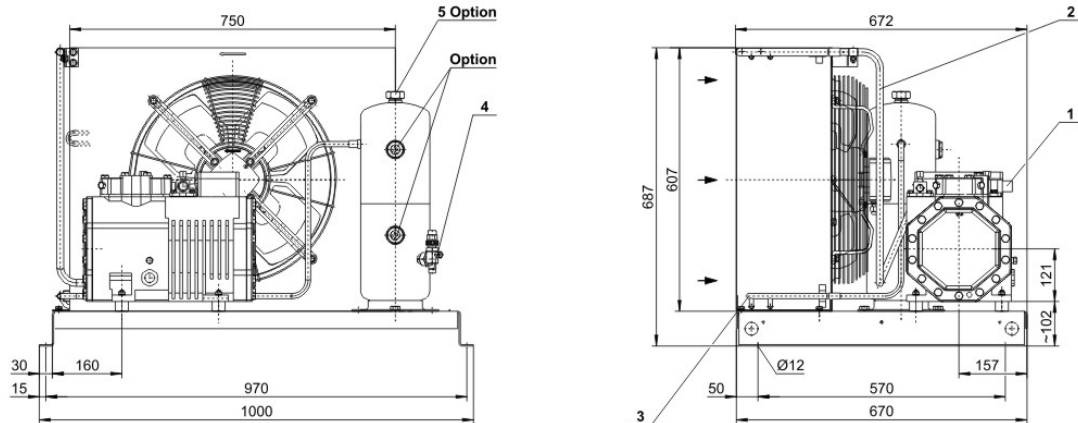

### Technical Data

#### Technical Data

Weight	119 kg
Total width	1000 mm
Total depth	672 mm
Total height	687 mm
Connection suction line	22 mm - 7/8"
Connection liquid line	12 mm - 1/2"
Fans: Number	1xEC
Voltage (50Hz, more on request)	230V-1-50Hz (Standard)
Current / Power consumption of each fan (50Hz)	1,5 A / 315 W
Air flow condenser 50Hz	4300 m <sup>3</sup> /h
Voltage (60Hz, more on request)	230V-1-60Hz (Standard)
Current / Power consumption of each fan (60Hz)	1,8 A / 330 W
Air flow condenser 60Hz	3100 m <sup>3</sup> /h
Coil Volume	1,05 dm <sup>3</sup>
Receiver type (Standard)	FS76
Max. refrigerant charge 90% at 20°C / 68°F	
R22	8,5 kg
R134a	8,6 kg
R407C	8,1 kg
R404A/R507A	7,5 kg
R407A	8,2 kg
R407F	8 kg
R448A	7,8 kg
R449A	7,8 kg
R450A	8,4 kg
R513A	8,6 kg
R1234yf	7,8 kg
R1234ze	8,3 kg
Receiver type (Option)	FS125
R22	14,2 kg
R134a	14,3 kg
R407C	13,6 kg
R404A/R507A	12,5 kg

#### Extent of delivery (Standard)

Discharge line	Standard
Protective charge	Standard

#### Available Options

Oil separator	Option
Check valve	Option
High & low pressure switch	Option
Dressed unit	Option
Weather protective housing	Option
Fans: elect. Speed control	Option

#### Sound measurement

Data of compressors: see compressor program



## Condensing Units

**Motor 1** = e.g. LH..E/4TES-12 with 12 "HP", primary for air-conditioning (e.g. R22,R407C) and medium temperature application (e.g. R134a, R407F, R407A, R404A, R507A, R22) and air-conditioning with R134a at high ambient temperatures.

**Motor 2** = e.g. LH..E/4TES-9 with 8 "HP", for medium and low temperature application (e.g. R134a, R407F, R407A, R404A, R507A, R22) and air-conditioning with R134a.

For more information concerning the application range use the "limits" button.

### Operation modes for LH..E/4VES-7 to LH../6HE-28 with R22

CIC = liquid injection with low temperature application, suction gas cooled motor

### Specifications for sound emission Ecostar

The data are based on 50 Hz operation with R404A.

Soundpressure: Data are valid for free field conditions according to EN13487 with a block-shaped reference area in a distance of 10m.

For further informations see technical information for sound data.

### Legend of connection positions according to "Dimensions":

- 1 Suction gas valve
- 2 Discharge gas line
- 3 Condensate line
- 4 Refrigerant outlet (liquid line)
- 5 Pressure relief valve connection
- 6 Liquid injection (operation without liquid subcooler and with thermostatic expansion valve)
- 7 Refrigerant inlet at liquid subcooler
- 8 Refrigerant outlet at liquid subcooler
- 9 Suction gas line
- 10 Sight glass
- 11 Load suspension points
- 12 Plug for screwed cable gland
- 13 Cable bushing (for cables  $\varnothing$  9-17 mm) (only ECOLITE)

Dimensions can show tolerances according to EN ISO 13920-B.