

Condensing unit
Voltage Code : XG

WINFH4532Z-XG

High Temp. Commercial (HP)

380-420V 3~ 50Hz / 460V 3~ 60 Hz

R452A / R404A / R448A / R449A

WINFH4532Z-XG

Conditions	Frequency	Nominal Cooling Capacity		Sound Power ISO3745 / ISO 3743-1
		Watts	BTU/h	
EN13215 / R452A	50 Hz	3736	12740	71 dBA
EN13215 / R404A	50 Hz	4129	14080	71 dBA
EN13215 / R448A	50 Hz	3642	12420	71 dBA
EN13215 / R449A	50 Hz	3634	12392	71 dBA

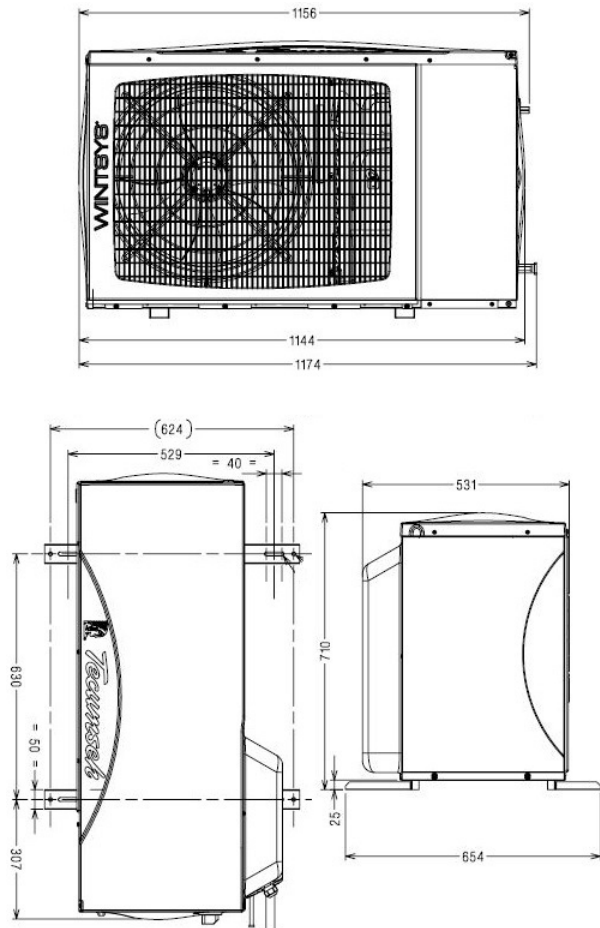

* EN13215 : T°Ambient 32.0°C / T°Evap. -10.0°C / T°Return gas temp.. 20.0°C
T°Subcooling. 3.0K

Net Weight (Kg)	80.0
Expansion device	Expansion_Valve
Air Flow (m³/h)	2750 / 2750
Elec Comp Type	TRI
Current (Amp)	
Load Rated Amp	4.6
Max Cont Current	7.8
Lock Rotor Amp	30
Fan	
Speed (rpm)	830 / 830
Power (W)	125.0
Diameter (mm)	450
Protection	Overload
IP Level	IP44
Condenser	450/17000
Liquid Receiver	
Capacity (L)	3.9
Maximum Pressure (Bars)	32.0
Suction Line	
Suction Type	Tube / Tube
For Tubing Out Diam	22.2 (7/8")
Suction Connection Type	Brased
Liquid Line	
Liquid Line Type	Tube
For Tubing Out Diam	12.7 (1/2")
Liquid Connecton Type	Brased
Connection Type	TT
Fan Guard	maille < à 8mm

Note : Tecumseh reserves the right to change information contained in this document without notification.



Tecumseh

WINFH4532Z-XG	Tension XG : 380-420V 3~ 50Hz / 460V 3~ 60 Hz
----------------------	--

Les performances sont données dans les conditions EN13215 :	Gaz aspirés :	20.0 °C
Condition Dew	Sous refroidissement :	3.0 K
The performance data are in EN13215 conditions :	Return gas :	20.0 °C
Dew Condition	Subcooling :	3.0 K

© 2023 Tecumseh Products Company
All rights reserved

50 Hz R452A											
											N°User-294
5 T ambience	6 T évaporation	(°C)	-25	-20	-15	-10	-5	0	5	10	15
25	1 P frigorifique	(Watt)	2090	2726	3437	4222	5078	6003	7000	8078	9253
	2 P absorbée	(W)	1213	1403	1594	1788	1987	2190	2397	2609	2824
	3 I absorbée	(A)	2.99	3.22	3.45	3.69	3.94	4.20	4.48	4.77	5.07
	4 Tc	(°C)	29.1	31.3	33.6	36.0	38.4	40.7	43.1	45.4	47.6
32	1 P frigorifique	(Watt)		2351	3015	3736	4513	5347	6244	7212	8272
	2 P absorbée	(W)		1432	1644	1857	2074	2293	2516	2742	2971
	3 I absorbée	(A)		3.23	3.50	3.78	4.06	4.35	4.65	4.96	5.27
	4 Tc	(°C)		37.4	39.5	41.7	43.9	46.1	48.3	50.5	52.6
43	1 P frigorifique	(Watt)			2359	2979	3635	4330	5073	5881	6779
	2 P absorbée	(W)			1698	1946	2194	2443	2693	2944	3196
	3 I absorbée	(A)			3.55	3.88	4.22	4.56	4.90	5.24	5.59
	4 Tc	(°C)			48.8	50.7	52.7	54.7	56.6	58.6	60.4

50 Hz R404A											
											N°User-293
5 T ambience	6 T évaporation	(°C)	-25	-20	-15	-10	-5	0	5	10	15
25	1 P frigorifique	(Watt)	2431	3083	3825	4649	5550	6524	7569	8687	9888
	2 P absorbée	(W)	1285	1467	1649	1833	2018	2206	2395	2585	2776
	3 I absorbée	(A)	3.15	3.35	3.56	3.78	4.01	4.25	4.49	4.75	5.01
	4 Tc	(°C)	29.7	31.9	34.0	36.3	38.5	40.8	43.0	45.2	47.4
32	1 P frigorifique	(Watt)	2079	2695	3380	4129	4940	5809	6737	7729	8795
	2 P absorbée	(W)	1307	1508	1709	1911	2114	2319	2524	2730	2936
	3 I absorbée	(A)	3.15	3.39	3.63	3.88	4.14	4.40	4.67	4.95	5.24
	4 Tc	(°C)	36.1	38.0	40.0	42.0	44.1	46.2	48.3	50.3	52.3
43	1 P frigorifique	(Watt)			2674	3306	3975	4682	5429	6227	7091
	2 P absorbée	(W)			1791	2023	2255	2487	2719	2951	3183
	3 I absorbée	(A)			3.72	4.02	4.33	4.64	4.95	5.26	5.58
	4 Tc	(°C)			49.3	51.0	52.9	54.7	56.5	58.4	60.2

1 = cooling capacity 2 = power input 3 = current 4 = condensing temperature 5 = ambient temperature 6 = evaporating temperature

Nota : Tecumseh se réserve le droit de modifier les informations contenues dans ce document sans préavis.
Note : Tecumseh reserves the right to change information contained in this document without notification.



Tecumseh

WINFH4532Z-XG	Tension XG : 380-420V 3~ 50Hz / 460V 3~ 60 Hz
----------------------	--

Les performances sont données dans les conditions EN13215 :	Gaz aspirés :	20.0 °C
Condition Dew	Sous refroidissement :	3.0 K
The performance data are in EN13215 conditions :	Return gas :	20.0 °C
Dew Condition	Subcooling :	3.0 K

50 Hz R448A (*)											
											N°User-296
5 T ambience	6 T évaporation	(°C)	-25	-20	-15	-10	-5	0	5	10	15
25	1 P frigorifique	(Watt)	1903	2539	3265	4085	5000	6013	7128	8357	9717
	2 P absorbée	(W)	1150	1317	1487	1663	1845	2033	2227	2426	2628
	3 I absorbée	(A)	2.87	3.07	3.27	3.48	3.72	3.96	4.22	4.49	4.77
	4 Tc	(°C)	27.1	28.9	31.0	33.2	35.5	37.9	40.4	42.7	45.0
32	1 P frigorifique	(Watt)		2205	2884	3642	4483	5410	6430	7555	8804
	2 P absorbée	(W)		1354	1544	1738	1938	2145	2358	2576	2797
	3 I absorbée	(A)		3.10	3.33	3.58	3.84	4.12	4.41	4.70	5.01
	4 Tc	(°C)		35.4	37.2	39.2	41.4	43.6	45.8	48.1	50.2
43	1 P frigorifique	(Watt)			2288	2951	3676	4471	5343	6307	
	2 P absorbée	(W)			1617	1844	2076	2315	2560	2810	
	3 I absorbée	(A)			3.42	3.72	4.03	4.36	4.69	5.04	
	4 Tc	(°C)			47.0	48.7	50.6	52.5	54.6	56.6	

50 Hz R449A (*)											
											N°User-295
5 T ambience	6 T évaporation	(°C)	-25	-20	-15	-10	-5	0	5	10	15
25	1 P frigorifique	(Watt)	1901	2535	3260	4077	4989	5997	7108	8333	9688
	2 P absorbée	(W)	1150	1317	1489	1665	1848	2037	2232	2432	2635
	3 I absorbée	(A)	2.87	3.07	3.27	3.49	3.72	3.97	4.23	4.50	4.78
	4 Tc	(°C)	27.2	29.0	31.1	33.3	35.7	38.1	40.5	42.9	45.2
32	1 P frigorifique	(Watt)		2201	2878	3634	4471	5394	6409	7529	8772
	2 P absorbée	(W)		1355	1545	1740	1941	2149	2363	2582	2805
	3 I absorbée	(A)		3.10	3.34	3.58	3.85	4.12	4.41	4.71	5.02
	4 Tc	(°C)		35.5	37.3	39.3	41.5	43.7	46.0	48.2	50.4
43	1 P frigorifique	(Watt)			2282	2942	3664	4454	5320	6278	
	2 P absorbée	(W)			1618	1845	2079	2319	2565	2816	
	3 I absorbée	(A)			3.42	3.72	4.03	4.36	4.70	5.05	
	4 Tc	(°C)			47.1	48.8	50.7	52.7	54.7	56.7	

1 = cooling capacity 2 = power input 3 = current 4 = condensing temperature 5 = ambient temperature 6 = evaporating temperature

(*) Veuillez vous référer strictement aux Recommandations d'Utilisation et Bulletins Marketing Tecumseh du fait de la température de reflux élevée pour les applications LBP.
 (*) Due to very high discharge temperature especially on LBP conditions, please strictly refer to Tecumseh Guidelines & Marketing Bulletin when using this refrigerant.

Nota : Tecumseh se réserve le droit de modifier les informations contenues dans ce document sans préavis.
Note : Tecumseh reserves the right to change information contained in this document without notification.

© 2023 Tecumseh Products Company
All rights reserved