



**BITZER Output data**

Created on : 06.01.2020 14:18:24



## Table of content

Project survey.....	3
Selection: Condensing Units.....	4
Technical Data: LH84E/4DES-5Y.....	5
Information: Condensing Units.....	6



## Project survey

### ***Selected compressors***

Condensing Units

1x LH84E/4DES-5Y



### Selection: Condensing Units

#### Input Values

Unit type	LH84E/4DES-5Y	Useful superheat	100%
Series	Standard	Operating mode	Auto
Refrigerant	R449A	Power supply	400V-3-50Hz
Reference temperature	Dew point temp.	Capacity control	100%
Suction gas temperature	20,00 °C		

#### Result

Q [W]	Cooling capacity	Op.	Operating mode
P [kW]	Power input	tc [°C]	Condensing SDT
I [A]	Current	dtau [K]	subcooling
m [kg/h]	Mass flow		

tamb	to	10°C	5°C	0°C	-5°C	-10°C	-15°C	-20°C	-25°C
27°C	Q [W]	--	--	18309	15542	13007	10715	8671	6870
	P [kW]	--	--	7,12	6,39	5,70	5,04	4,43	3,84
	I [A]	--	--	11,49	10,41	9,41	8,49	7,66	6,93
	m [kg/h]	--	--	435	353	285	228	179,2	138,8
	Op.	--	--	Standard	Standard	Standard	Standard	Standard	Standard
	tc [°C]	--	--	50,0	47,1	44,4	41,9	39,7	37,8
	dtau [K]	--	--	3,00	3,00	3,00	3,00	3,00	3,00
32°C	Q [W]	--	--	--	14448	12064	9907	7984	6292
	P [kW]	--	--	--	6,63	5,89	5,19	4,53	3,91
	I [A]	--	--	--	10,78	9,69	8,70	7,80	7,00
	m [kg/h]	--	--	--	345	277	220	172,4	132,7
	Op.	--	--	--	Standard	Standard	Standard	Standard	Standard
	tc [°C]	--	--	--	51,3	48,7	46,3	44,2	42,3
	dtau [K]	--	--	--	3,00	3,00	3,00	3,00	3,00
43°C	Q [W]	--	--	--	--	10005	8160	6512	5064
	P [kW]	--	--	--	--	6,23	5,43	4,67	3,96
	I [A]	--	--	--	--	10,19	9,03	7,99	7,07
	m [kg/h]	--	--	--	--	258	203	156,8	118,8
	Op.	--	--	--	--	Standard	Standard	Standard	Standard
	tc [°C]	--	--	--	--	58,2	56,1	54,1	52,3
	dtau [K]	--	--	--	--	3,00	3,00	3,00	3,00

-- No calculation possible (see message in single point selection)  
 Power input compressor, power input fan see "T. Data"

### Application Limits 1 LH84E/4DES-5

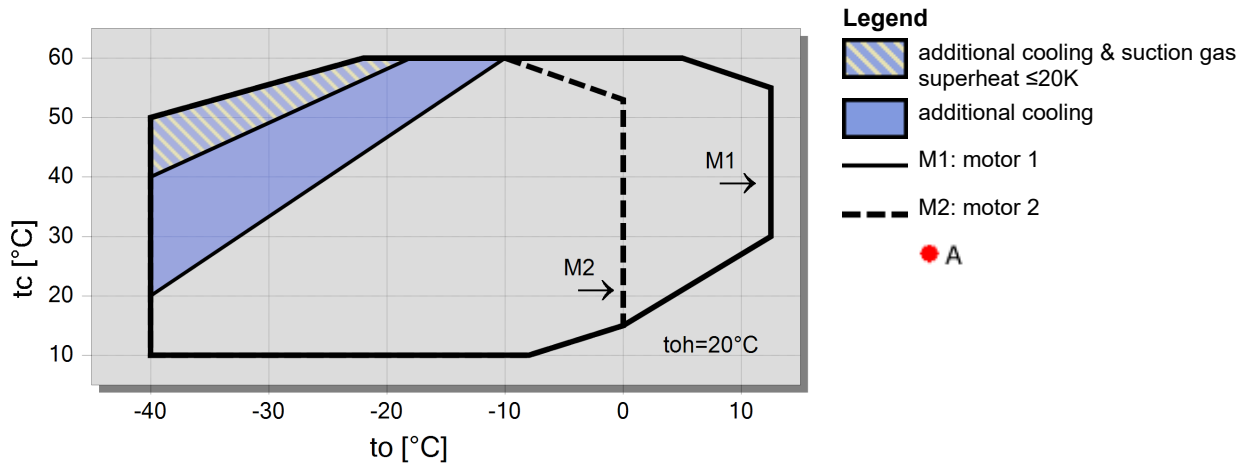



## Technical Data: LH84E/4DES-5Y

### Dimensions and Connections

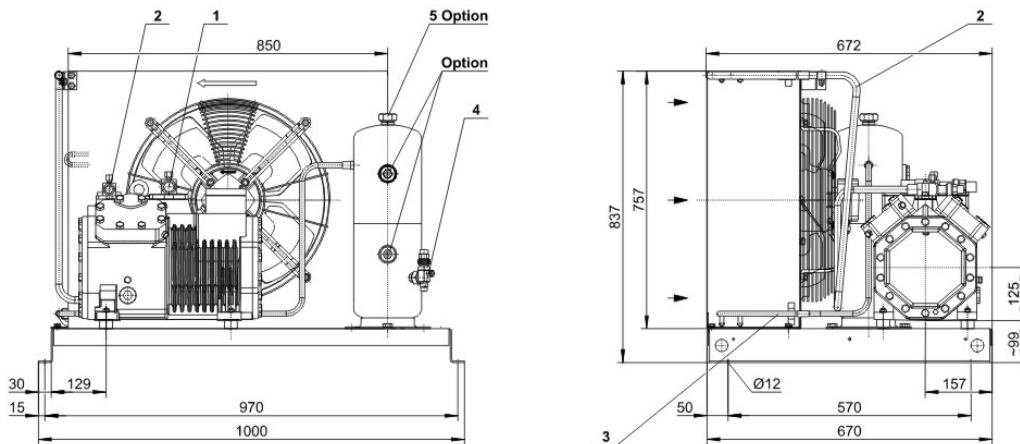

### Technical Data

#### Technical Data

Weight	143 kg
Total width	1000 mm
Total depth	672 mm
Total height	837 mm
Connection suction line	28 mm - 1 1/8"
Connection liquid line	12 mm - 1/2"
Fans: Number	1xEC
Voltage (50Hz, more on request)	230V-1-50Hz (Standard)
Current / Power consumption of each fan (50Hz)	1,5 A / 330 W
Air flow condenser 50Hz	4600 m <sup>3</sup> /h
Voltage (60Hz, more on request)	230V-1-60Hz (Standard)
Current / Power consumption of each fan (60Hz)	1,7 A / 340 W
Air flow condenser 60Hz	4600 m <sup>3</sup> /h
Coil Volume	2,23 dm <sup>3</sup>
Receiver type (Standard)	FS126
Max. refrigerant charge 90% at 20°C / 68°F	
R22	14,2 kg
R134a	14,3 kg
R407C	13,6 kg
R404A/R507A	12,5 kg
R407A	13,7 kg
R407F	13,3 kg
R448A	13 kg
R449A	13,1 kg
R450A	14 kg
R513A	14,3 kg
R1234yf	13 kg
R1234ze	13,8 kg
Receiver type (Option)	FS202
R22	21,8 kg
R134a	22,1 kg
R407C	20,9 kg
R404A/R507A	19,2 kg

#### Extent of delivery (Standard)

Discharge line	Standard
Protective charge	Standard

#### Available Options

Oil separator	Option
Check valve	Option
High & low pressure switch	Option
Dressed unit	Option
Weather protective housing	Option
Fans: elect. Speed control	Option

#### Sound measurement

Data of compressors: see compressor program



## Condensing Units

**Motor 1** = e.g. LH..E/4TES-12 with 12 "HP", primary for air-conditioning (e.g. R22,R407C) and medium temperature application (e.g. R134a, R407F, R407A, R404A, R507A, R22) and air-conditioning with R134a at high ambient temperatures.

**Motor 2** = e.g. LH..E/4TES-9 with 8 "HP", for medium and low temperature application (e.g. R134a, R407F, R407A, R404A, R507A, R22) and air-conditioning with R134a.

For more information concerning the application range use the "limits" button.

### Operation modes for LH..E/4VES-7 to LH../6HE-28 with R22

CIC = liquid injection with low temperature application, suction gas cooled motor

### Specifications for sound emission Ecostar

The data are based on 50 Hz operation with R404A.

Soundpressure: Data are valid for free field conditions according to EN13487 with a block-shaped reference area in a distance of 10m.

For further informations see technical information for sound data.

### Legend of connection positions according to "Dimensions":

- 1 Suction gas valve
- 2 Discharge gas line
- 3 Condensate line
- 4 Refrigerant outlet (liquid line)
- 5 Pressure relief valve connection
- 6 Liquid injection (operation without liquid subcooler and with thermostatic expansion valve)
- 7 Refrigerant inlet at liquid subcooler
- 8 Refrigerant outlet at liquid subcooler
- 9 Suction gas line
- 10 Sight glass
- 11 Load suspension points
- 12 Plug for screwed cable gland
- 13 Cable bushing (for cables  $\varnothing$  9-17 mm) (only ECOLITE)

Dimensions can show tolerances according to EN ISO 13920-B.