

AIR CONDITIONER

**Wall mounted type**

# SERVICE MANUAL

---

*For Cold Climate Region*

---

INDOOR



ASYG09KMCDN  
ASYG12KMCDN  
ASYG14KMCDN

---

OUTDOOR



AOYG09KMCDN



AOYG12KMCDN



AOYG14KMCDN

---

**Notices:**

- Product specifications and design are subject to change without notice for future improvement.
- For further details, please check with our authorized dealer.

# CONTENTS

**1. GENERAL INFORMATION**

**2. TECHNICAL DATA AND PARTS LIST**

**3. TROUBLESHOOTING**

**4. CONTROL AND FUNCTIONS**

**5. FIELD WORKING**



## **1. GENERAL INFORMATION**

# CONTENTS

## 1. GENERAL INFORMATION

<b>1. Specifications</b> .....	<b>01-1</b>
1-1. Indoor unit .....	01-1
1-2. Outdoor unit.....	01-3
<b>2. Dimensions</b> .....	<b>01-4</b>
2-1. Indoor unit .....	01-4
2-2. Outdoor unit.....	01-6

# 1. Specifications

## 1-1. Indoor unit

Type				Wall mounted			
				Inverter heat pump			
Model name				ASYG09KMCDN	ASYG12KMCDN	ASYG14KMCDN	
Power supply				230 V~ 50 Hz			
Power supply intake				Outdoor unit			
Available voltage range				198—264 V			
Capacity	Cooling	Rated	kW	2.5	3.4	4.2	
			Btu/h	8,500	11,600	14,300	
		Min.—Max.	kW	1.00—3.80	1.00—4.20	1.20—4.65	
	Heating	Rated	Btu/h	3,400—13,000	3,400—14,300	4,100—15,900	
			kW	3.2	4.0	5.4	
		Min.—Max.	kW	0.9—5.7	0.9—5.9	0.9—6.4	
Input power	Cooling	Rated	kW	0.54	0.80	1.10	
			Btu/h	10,900	13,600	18,400	
		Min.—Max.	kW	0.21—1.08	0.21—1.25	0.26—1.25	
	Heating	Rated	kW	0.72	0.96	1.40	
			Btu/h	3,100—19,400	3,100—20,100	3,100—21,800	
		Min.—Max.	kW	0.180—2.350	0.180—1.800	0.185—1.900	
Current	Cooling	Rated	A	2.5	3.6	4.9	
	Heating		A	3.3	4.3	6.2	
EER	Cooling	kW/kW		4.63	4.25	3.82	
COP	Heating			4.44	4.17	3.86	
Sensible capacity	Cooling	kW		2.37	2.74	3.26	
Power factor	Cooling	%		94	96	97	
	Heating			95	97	98	
Moisture removal		L/h (pints/h)		1.3 (2.3)	1.8 (3.2)	2.1 (3.7)	
Maximum operating current *1	Cooling	A		6.0	7.0	8.5	
	Heating			9.5	11.5	16.0	
Fan	Airflow rate	Cooling	HIGH	670	690	770	
			MED	530	560	600	
			LOW	410	450	450	
			QUIET	280	280	280	
		Heating	HIGH	750	780	820	
			MED	620	630	650	
			LOW	510	520	520	
			QUIET	290	290	340	
	Type × Qty	Crossflow fan × 1					
	Motor output	W		27			
Sound pressure level *2	Cooling	HIGH	40	42	43		
		MED	36	37	40		
		LOW	30	32	33		
		QUIET	20	20	20		
	Heating	HIGH	42	43	44		
		MED	38	39	40		
		LOW	33	35	35		
		QUIET	22	22	24		
		Heat exchanger type	Dimensions (H × W × D)	mm	Main 1: 210 × 670 × 26.6 Main 2: 112 × 670 × 20 Sub 1: 84 × 670 × 13.3		
			Fin pitch		Man 1: 1.2 Main 2: 1.1 Sub 1: 1.4		
Rows × Stages	Main 1: 2 × 10 Main 2: 2 × 7 Sub 1: 1 × 4						
Pipe type	Copper tube						
Fin type	Aluminum						
Enclosure	Material	Polystyrene					
	Color	White Approximate color of Munsell N 9.25/					
Dimensions (H × W × D)	Net	mm	270 × 834 × 222				
	Gross		277 × 914 × 332				
Weight	Net	kg	10.0				
	Gross		13.0				
Connection pipe	Size	Liquid	Ø6.35 (Ø1/4)				
		Gas	Ø9.52 (Ø3/8)				
	Method	Flare					
Drain hose	Material	PP+HDPE					
	Tip diameter	mm	Ø13.8 (I.D.), Ø15.8 to Ø16.7 (O.D.)				
Operation range	Cooling	°C	18 to 32				
		%RH	80 or less				
	Heating	°C	16 to 30				
Remote controller type	Wireless (Wired, Mobile app*3 [FGLair™] [option])						

### NOTES:

- Specifications are based on the following conditions:
  - Cooling: Indoor temperature of 27°CDB/19°CWB, and outdoor temperature of 35°CDB/24°CWB.
  - Heating: Indoor temperature of 20°CDB/15°CWB, and outdoor temperature of 7°CDB/6°CWB.
  - Pipe length: 5 m, Height difference: 0 m. (Between outdoor unit and indoor unit.)
- Protective function might work when using it outside the operation range.
- \*1: Maximum current is maximum value when operated within the operation range.
- \*2: Sound pressure level:
  - Measured values in manufacturer's anechoic chamber.
  - Because of the surrounding sound environment, the sound levels measured in actual installation conditions might be higher than the specified values here.
- \*3: Available on Google Play™ store or on App Store®.

Specifications for Lot10						
Model name		ASYG09KMCDN	ASYG12KMCDN	ASYG14KMCDN		
Energy efficiency class	Cooling	A++				
	Heating (Average)	A++				
Pdesign	Cooling	kW	2.5 (35°C)	3.4 (35°C)	4.2 (35°C)	
	Heating (Average)		2.5 (-10°C)	3.6 (-10°C)	4.2 (-10°C)	
SEER	Cooling	kWh/kWh	6.5	7.5	7.3	
SCOP	Heating (Average)		4.6	4.6	4.6	
Annual energy consumption	QCE	kWh/a	135	159	201	
	QHE (Average)		761	1,096	1,278	
Sound power level	Cooling	HIGH	dB (A)	55	56	58
	Heating			57	58	60



## 1-2. Outdoor unit

Type			Inverter, Heat pump		
Model name			AOYG09KMCDN	AOYG12KMCDN	AOYG14KMCDN
Power supply			230 V~ 50 Hz		
Power supply intake			Outdoor unit		
Available voltage range			198—264 V		
Starting current			A	3.3	4.3
Fan	Airflow rate	Cooling	m <sup>3</sup> /h	1,770	2,210
		Heating		1,313	1,335
	Type × Qty		Propeller fan × 1		
	Motor output		W	23	49
Sound pressure level *	Cooling	Heating	dB (A)	48	49
				43	49
Sound power level	Cooling	Heating	dB (A)	59	61
				56	59
Heat exchanger type	Dimensions (H × W × D)		mm	Main 1: 504 × 881 × 18.19	Main 1: 588 × 881 × 18.19
	Main 2: 504 × 851 × 18.19			Main 2: 588 × 851 × 18.19	Main 2: 672 × 881 × 18.19
	Fin pitch		1.3		
	Rows × Stages		Main 1: 1 × 24	Main 1: 1 × 28	Main 1: 1 × 32
	Main 2: 1 × 24		Main 2: 1 × 28	Main 2: 1 × 32	
	Pipe type		Copper		
Compressor	Type	DC twin rotary			
		Motor output	W	810	900
Refrigerant	Type (Global warming potential)		R32 (675)		
	Charge	g	850	940	1,120
Refrigerant oil	Type		FW68S		RmM68AF
	Amount	cm <sup>3</sup>	350		400
Enclosure	Material		Steel sheet		
	Color		Beige Approximate color of Munsell 10YR 7.5/1.0		
Dimensions (H × W × D)	Net	mm	542 × 799 × 290	632 × 799 × 290	716 × 820 × 315
	Gross		602 × 940 × 375	692 × 940 × 375	776 × 961 × 450
Weight	Net	kg	33	36	42
	Gross		37	41	47
Connection pipe	Size	Liquid	mm (in)	Ø6.35 (Ø1/4)	
		Gas		Ø9.52 (Ø3/8)	
	Method		Flare		
	Pre-charge length		m	15	
	Max. length			20	
	Max. height difference			15	
Additional charge		g/m	20		
Operation range	Cooling	Heating	°C	-10 to 43	
				-25 to 24	
<b>NOTES:</b>					
<ul style="list-style-type: none"> <li>Specifications are based on the following conditions: <ul style="list-style-type: none"> <li>– Cooling: Indoor temperature of 27°CDB/19°CWB, and outdoor temperature of 35°CDB/24°CWB.</li> <li>– Heating: Indoor temperature of 20°CDB/15°CWB, and outdoor temperature of 7°CDB/6°CWB.</li> <li>– Pipe length: 5 m, Height difference: 0 m.</li> </ul> </li> <li>Protective function might work when using it outside the operation range.</li> <li>*: Sound pressure level <ul style="list-style-type: none"> <li>– Measured values in manufacturer's anechoic chamber.</li> <li>– Because of the surrounding sound environment, the sound levels measured in actual installation conditions might be higher than the specified values here.</li> </ul> </li> </ul>					

## 2. Dimensions

### 2-1. Indoor unit

#### ■ Models: ASYG09KMCDN, ASYG12KMCDN, and ASYG14KMCDN

Unit: mm

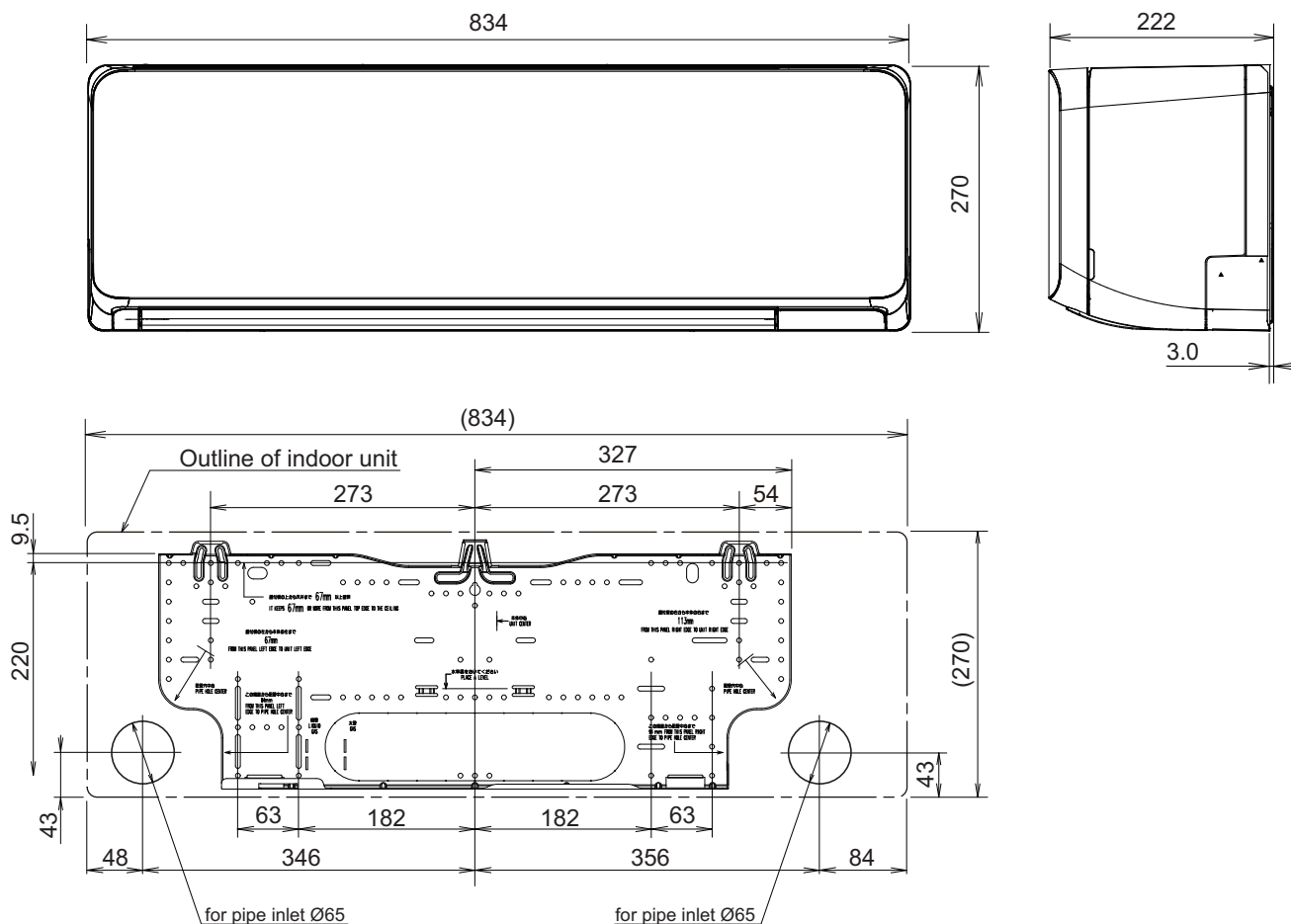

## ● Installation space requirement

Provide sufficient installation space for product safety.

Unit: mm

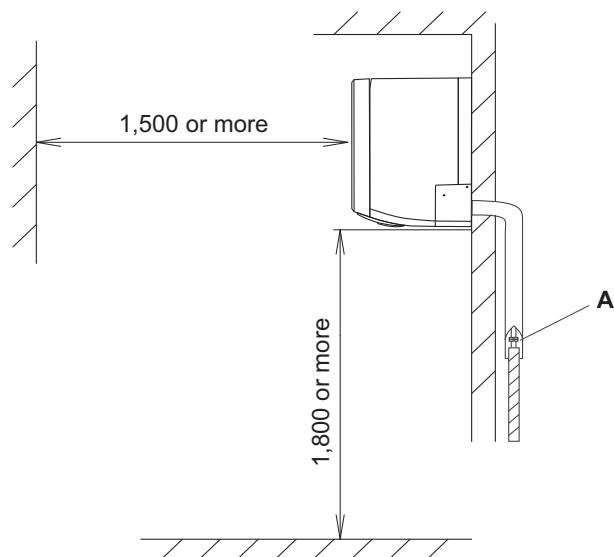
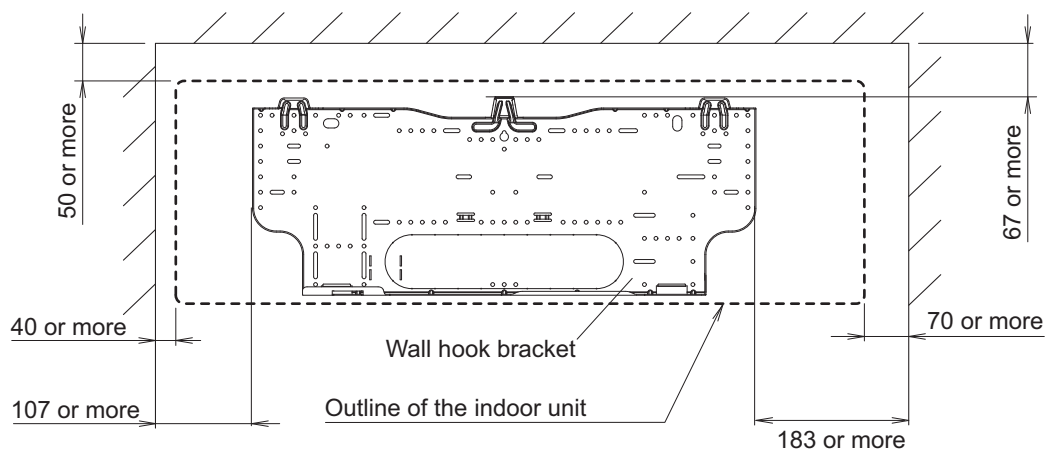

**A:** Install so that the flare connection part is outdoors.

## 2-2. Outdoor unit

### ■ Model: AOYG09KMCDN

Unit: mm

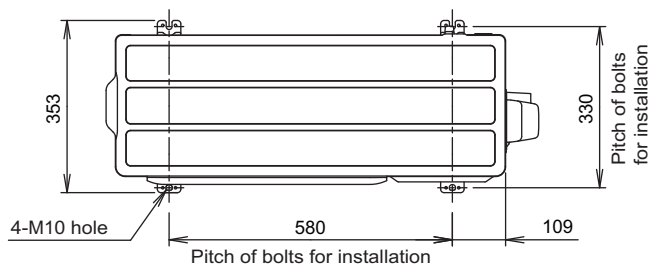

Top view

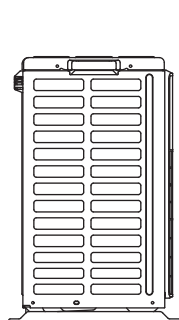

Side view

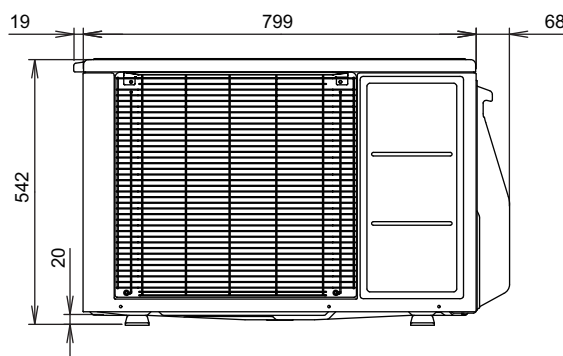

Front view

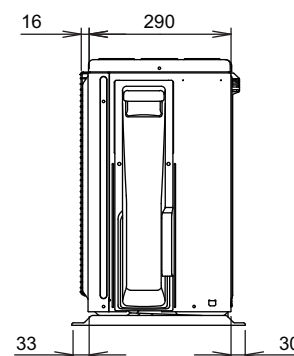

Side view

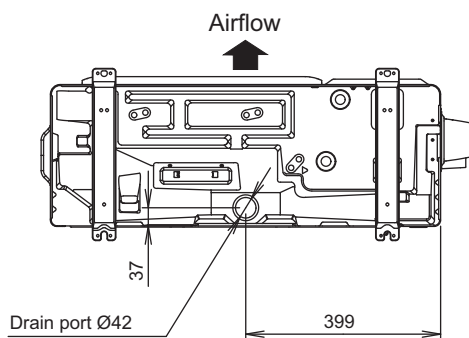

Bottom view

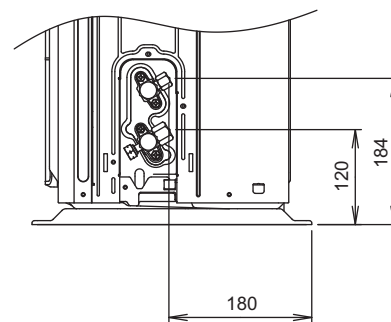

Side view (Valve part)

Model: AOYG12KMCDN

Unit: mm

GENERAL INFORMATION

GENERAL INFORMATION

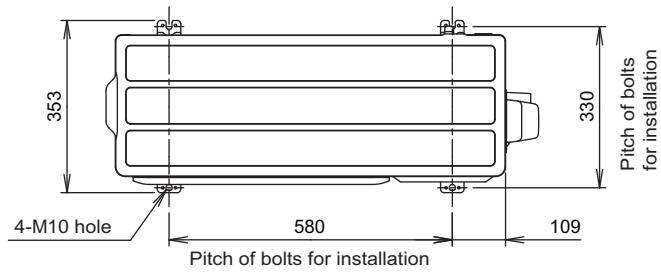

Top view

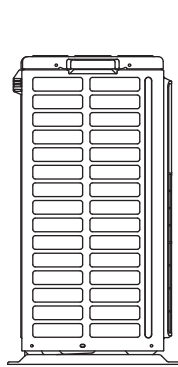

Side view

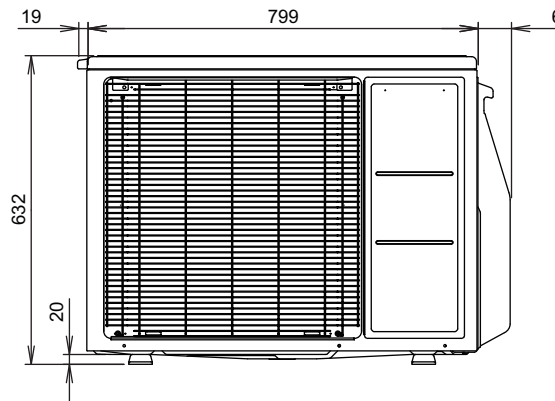

Front view

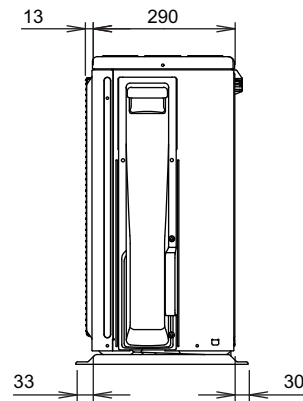

Side view

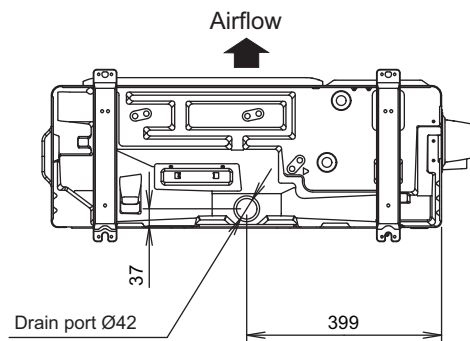

Bottom view

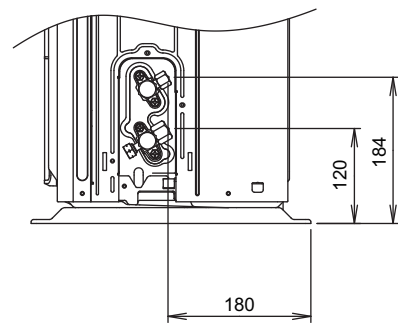

Side view (Valve part)

■ Model: AOYG14KMCDN

Unit: mm

GENERAL  
INFORMATION

GENERAL  
INFORMATION

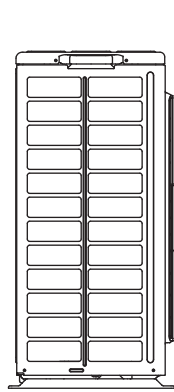
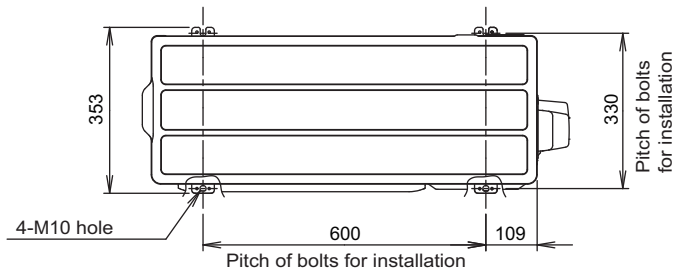

Side view

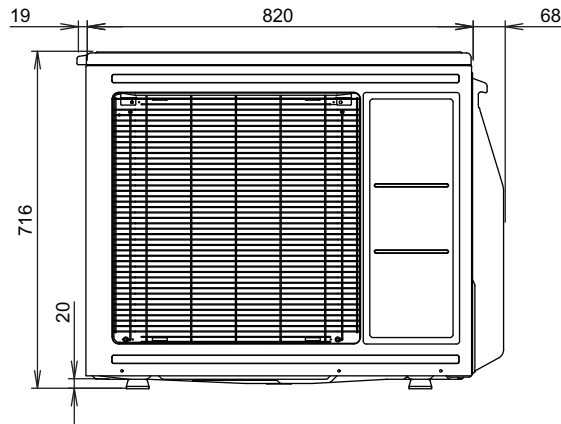

Front view

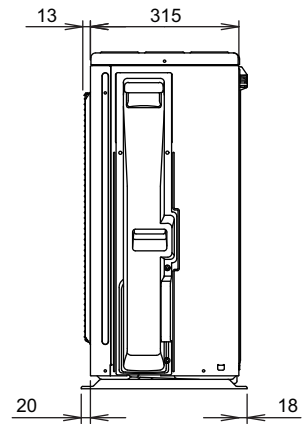

Side view

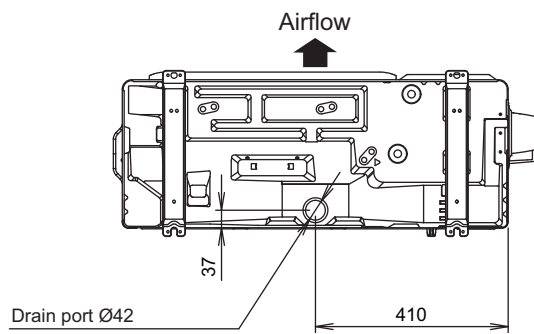

Bottom view

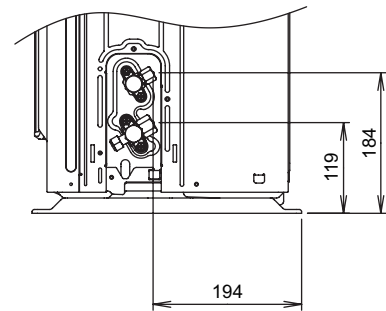

Side view (Valve part)

## **2. TECHNICAL DATA AND PARTS LIST**

# CONTENTS

## 2. TECHNICAL DATA AND PARTS LIST

<b>1. Precautions</b> .....	<b>02-1</b>
<b>2. Indoor unit parts list</b> .....	<b>02-2</b>
2-1. Models: ASYG09KMCDN, ASYG12KMCDN, and ASYG14KMCDN .....	02-2
<b>3. Outdoor unit parts list</b> .....	<b>02-4</b>
3-1. Model: AOYG09KMCDN .....	02-4
3-2. Model: AOYG12KMCDN .....	02-8
3-3. Model: AOYG14KMCDN .....	02-12
<b>4. Accessories</b> .....	<b>02-16</b>
4-1. Indoor unit .....	02-16
4-2. Outdoor unit.....	02-16
<b>5. Optional parts</b> .....	<b>02-17</b>
5-1. Indoor unit .....	02-17
<b>6. Refrigerant system diagrams</b> .....	<b>02-19</b>
6-1. Models: AOYG09KMCDN and AOYG12KMCDN .....	02-19
6-2. Model: AOYG14KMCDN .....	02-20
<b>7. Wiring diagrams</b> .....	<b>02-21</b>
7-1. Indoor unit .....	02-21
7-2. Outdoor unit.....	02-22
<b>8. PC board diagrams</b> .....	<b>02-24</b>
8-1. Models: ASYG09KMCDN, ASYG12KMCDN, and ASYG14KMCDN .....	02-24
8-2. Models: AOYG09KMCDN and AOYG12KMCDN .....	02-25
8-3. Model: AOYG14KMCDN .....	02-26



# 1. Precautions

When you start servicing, pay attention to the following points. For detailed precautions, refer to the installation manual of the products.

## CAUTION

- 
- Service personnel
    - Any person who is involved with working on or breaking into a refrigerant circuit should hold a current valid certificate from an industry-accredited assessment authority, which authorizes their competence to handle refrigerants safely in accordance with an industry recognized assessment specification.
    - Servicing shall only be performed as recommended by the equipment manufacturer. Maintenance and repair requiring the assistance of other skilled personnel shall be carried out under the supervision of the person competent in the use of flammable refrigerants.
    - Servicing shall be performed only as recommended by the manufacturer.
  - Work
    - Prior to beginning work on systems containing flammable refrigerants, safety checks are necessary to ensure that the risk of ignition is minimized. When repairing the refrigerant system, refer to the precautions written in the installation manual of the products before you start servicing.
    - Work shall be undertaken under a controlled procedure so as to minimize the risk of a flammable gas or vapor being present while the work is being performed.
    - All maintenance staff and others working in the local area shall be instructed on the nature of work being carried out.
    - Work in confined spaces shall be avoided.
    - The area around the workspace shall be sectioned off.
    - Ensure that the conditions within the area have been made safe by control of flammable material.
    - Electric shock may occur. After turning off the power, always wait 5 minutes before touching electrical components.
    - Do not touch the fins of the heat exchanger. Touching the heat exchanger fins could result in damage to the fins or personal injury such as skin rupture.
    - Do not place any other electrical products or household belongings under the product.
    - Condensation dripping from the product might get them wet, and may cause damage or malfunction to the property.
  - Checking for presence of refrigerant
    - The area shall be checked with an appropriate refrigerant leak detector prior to and during work, to ensure the technician is aware of potentially flammable atmospheres.
    - Ensure that the leak detector being used is suitable for use with flammable refrigerants, i.e. non-sparking, adequately sealed or intrinsically safe.
- 
- Service parts information and design are subject to change without notice for product improvement.
  - For the latest information of the service parts, refer to our Service Portal.  
<https://fujitsu-general.force.com/portal/>
  - Precise figure of the service parts listed in this manual may differ from the actual service parts.

## 2. Indoor unit parts list

### 2-1. Models: ASYG09KMCDN, ASYG12KMCDN, and ASYG14KMCDN

#### ■ Exterior parts

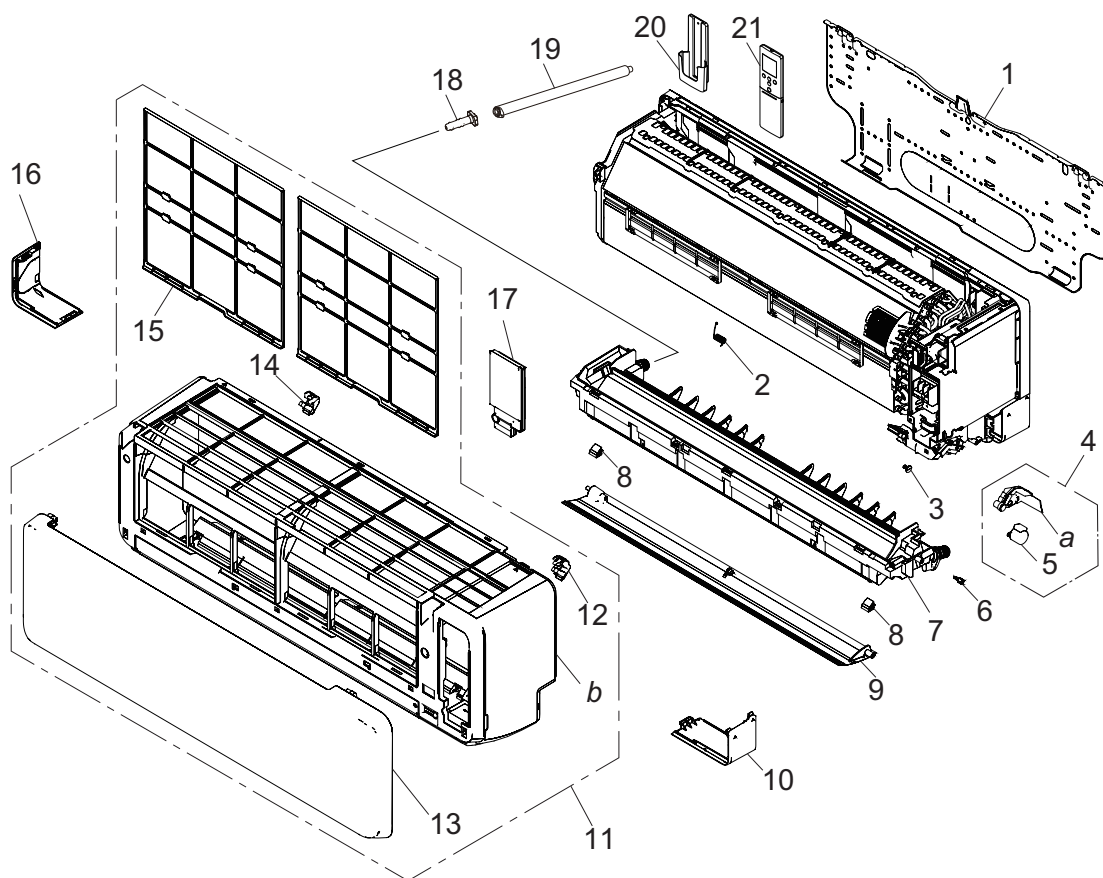

Item no.	Part no.	Part name	Service part
1	9387480047	Bracket panel	◆
2	9333951003	Louver spring P	◆
3	9333608006	Bush	◆
4	9387714043	Stepping motor holder assy	◆
5	9901011016	Stepping motor	◆
6	9332861006	Shaft cover	◆
7	9387590104	Drain pan total assy	◆
8	9387476002	Screw cover	◆
9	9387479041	Horizontal louver assy	◆
10	9387478006	Under cover R	◆
11	9387596939	Front panel total assy	◆
12	9333704005	Grille clamper R	◆
13	9323546004	Intake grille assy	◆
14	9333719009	Grille clamper L	◆
15	9387473018	Air filter	◆
16	9387477009	Under cover L	◆
17	9387597066	Wire cover assy	◆
18	9316177017	Drain cap	◆
19	9316904002	Drain hose assy	◆
20	9318912005	Remote controller holder	◆
21	9332438734	Remote controller	◆
a	—	Stepping motor holder	—
b	—	Front panel	—

## ■ Chassis

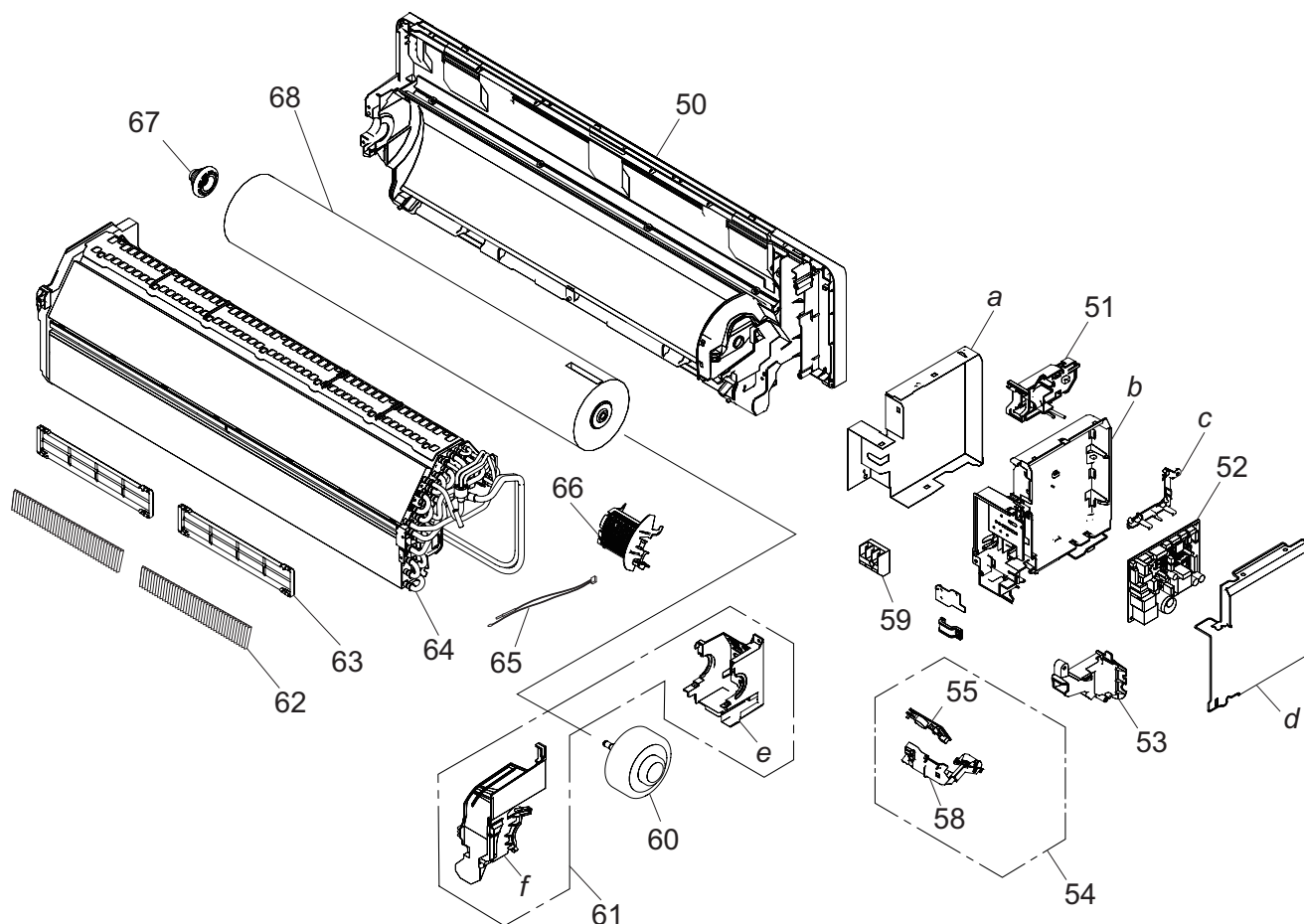

Item no.	Part no.	Part name	Service part
50	9387587074	Base assy	◆
51	9383765032	WLAN adapter holder assy	◆
52	9711141446	Main PCB (09 model)	◆
	9711141453	Main PCB (12 model)	◆
	9711141460	Main PCB (14 model)	◆
53	9387488029	Cable guide	◆
54	9711146021	Display assy	◆
55	9711147028	Indicator PCB	◆
58	9333879000	Display case assy	◆
59	9901013010	Terminal	◆
60	9603688028	DC fan motor (09 model)	◆
	9603492021	DC fan motor (12-14 model)	◆
61	9387589047	Motor case assy	◆
62	9317250009	Air clean filter assy	◆
63	9332911008	Electric filter holder	◆
64	9387593297	Evaporator total assy	◆
65	9900627065	Thermistor assy	◆
66	9387467017	Room thermistor holder	◆
67	9333628004	Bearing D assy	◆
68	9333606033	Crossflow fan assy	◆
—	9901010019	Wire with connector	◆
a	—	Box shield	—
b	—	Control box	—
c	—	PCB holder A	—
d	—	Control cover	—
e	—	Motor case	—
f	—	Motor cover	—

### 3. Outdoor unit parts list

#### 3-1. Model: AOYG09KMCDN

##### ■ Exterior parts and Chassis

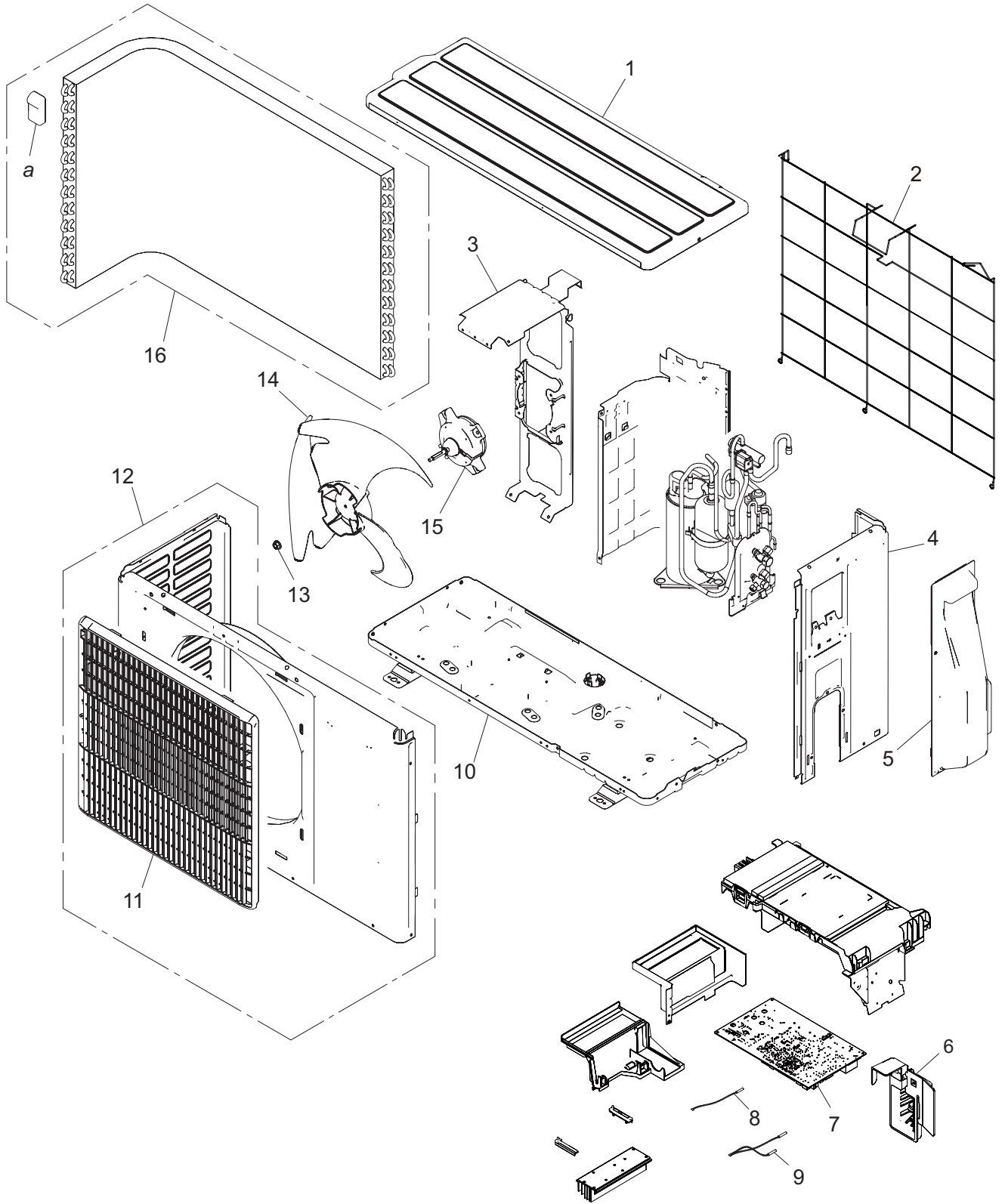

TECHNICAL DATA  
AND PARTS LIST

TECHNICAL DATA  
AND PARTS LIST

Item no.	Part no.	Part name	Service part
1	9322556028	Top panel assy	◆
2	9377840011	Protective net assy	◆
3	9322553287	Motor bracket assy	◆
4	9322552020	Cabinet right assy	◆
5	9322570000	Switch cover assy	◆
6	9322138002	Thermistor holder	◆
7	9709685686	Main PCB (Service)	◆
8	9900850012	Thermistor (Outdoor temp.)	◆
9	9900935047	Thermistor assy	◆
10	9323550032	Base assy	◆
11	9384265012	Fan guard	◆
12	9322555311	Front panel assy	◆
13	0700103070	Nut	◆
14	9322136008	Propeller fan	◆
15	9603553005	DC fan motor	◆
16	9323834019	Heat exchanger unit	◆
a	—	Hair pin cushion	—

# Compressor

TECHNICAL DATA  
AND PARTS LIST

TECHNICAL DATA  
AND PARTS LIST

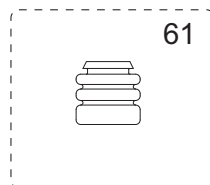
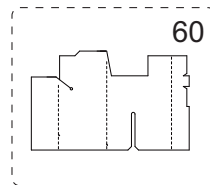
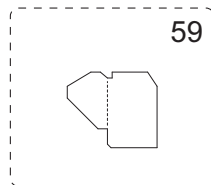
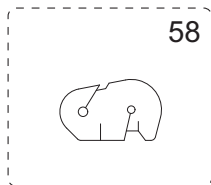
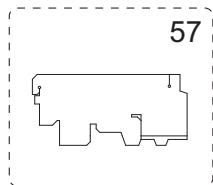
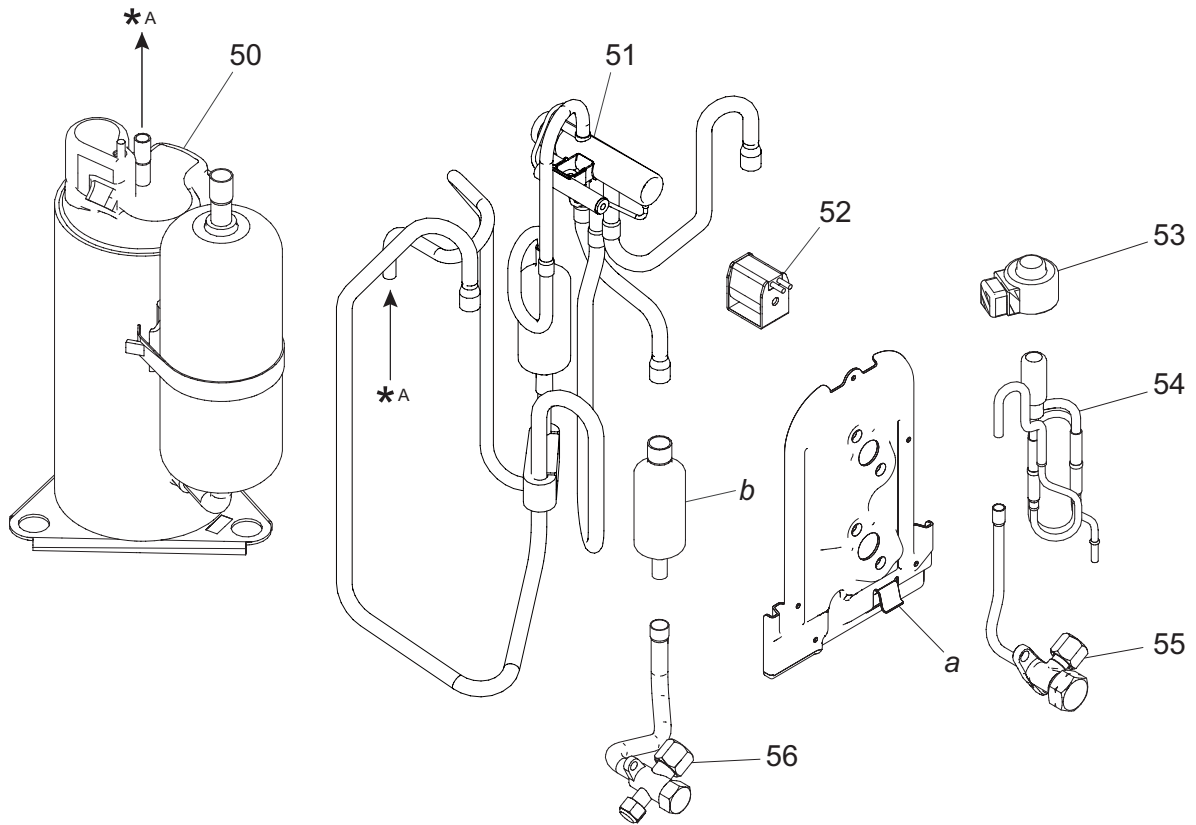

Item no.	Part no.	Part name	Service part
50	9322431004	Compressor assy	◆
51	9322445018	4-way valve assy	◆
52	9970194023	Solenoid	◆
53	9970095122	Expansion valve coil	◆
54	9322463005	Pulse motor valve assy	◆
55	9322474001	2-way valve assy	◆
56	9322475008	3-way valve assy	◆
57	9324024006	Sound insulator B	◆
58	9322537003	Sound insulator H	◆
59	9323045002	Sound insulator V	◆
60	9322536006	Sound insulator F	◆
61	9322386007	Cushion rubber	◆
62	9313437008	Nut special assy	◆
—	9901059049	Base pan heater	◆
—	9900934040	Wire with connector (Fuse holder)	◆
a	—	Valve bracket	—
b	—	Muffler	—

### 3-2. Model: AOYG12KMCDN

#### ■ Exterior parts and Chassis

TECHNICAL DATA  
AND PARTS LIST

TECHNICAL DATA  
AND PARTS LIST

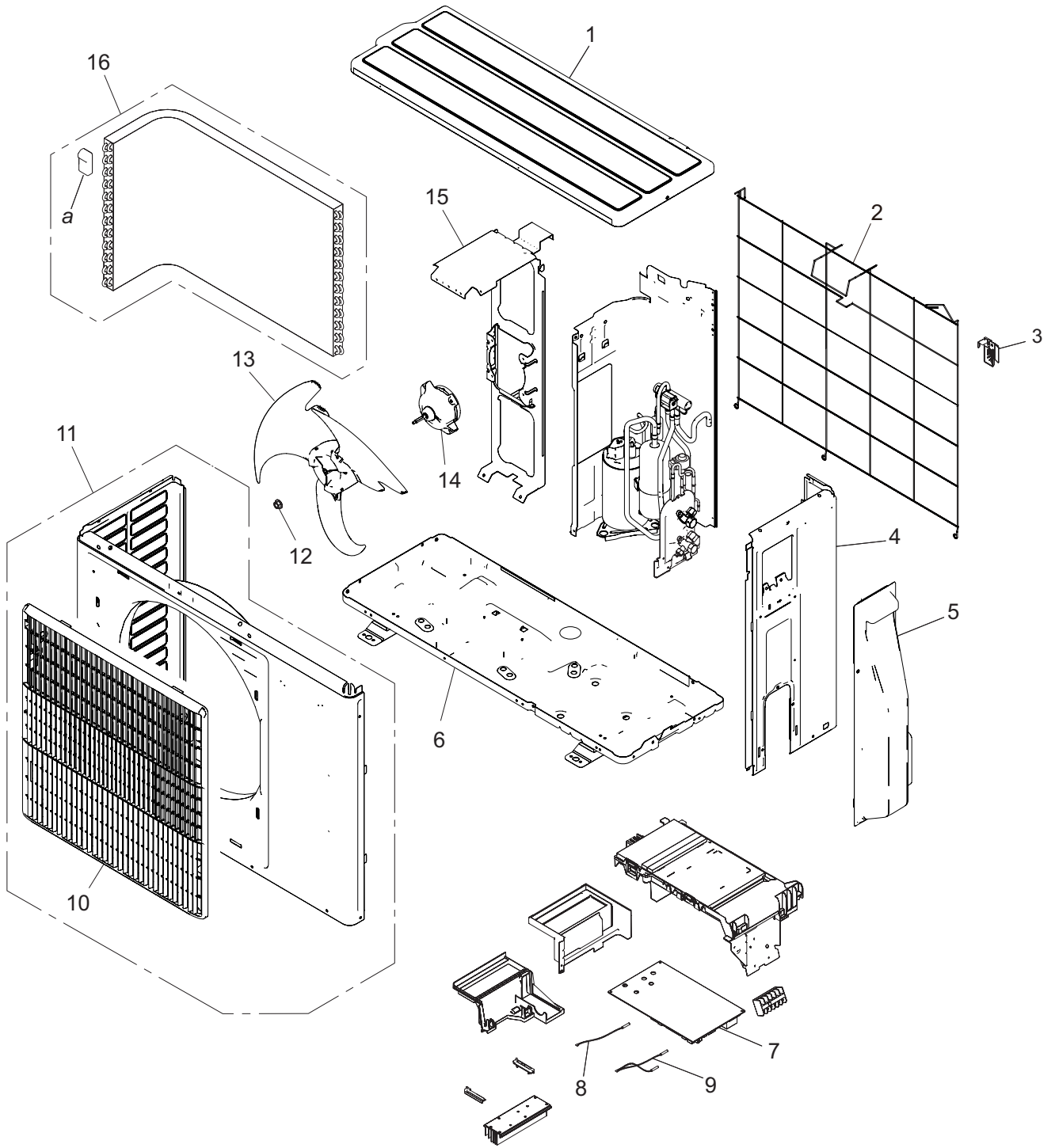



Item no.	Part no.	Part name	Service part
1	9322556066	Top panel assy	◆
2	9377854025	Protective net assy	◆
3	9322327000	Thermistor holder	◆
4	9322552099	Cabinet right assy	◆
5	9322570024	Switch cover assy	◆
6	9323550032	Base assy	◆
7	9709685693	Main PCB (Service)	◆
8	9900850012	Thermistor (Outdoor temp.)	◆
9	9900935054	Thermistor assy	◆
10	9384273017	Fan guard	◆
11	9384851000	Front panel assy	◆
12	0700103070	Nut	◆
13	9322150004	Propeller fan	◆
14	9603601003	DC fan motor	◆
15	9322553331	Motor bracket assy	◆
16	9323834026	Heat exchanger unit	◆
a	—	Hair pin cushion	—

# Compressor

TECHNICAL DATA  
AND PARTS LIST

TECHNICAL DATA  
AND PARTS LIST

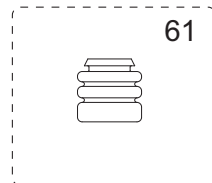
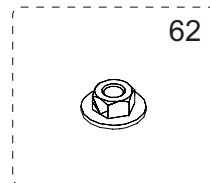
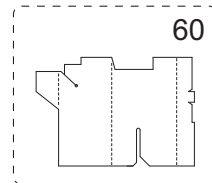
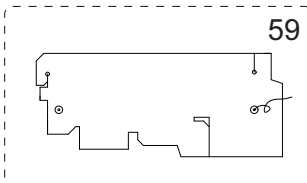
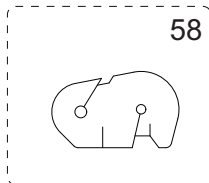
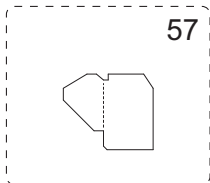
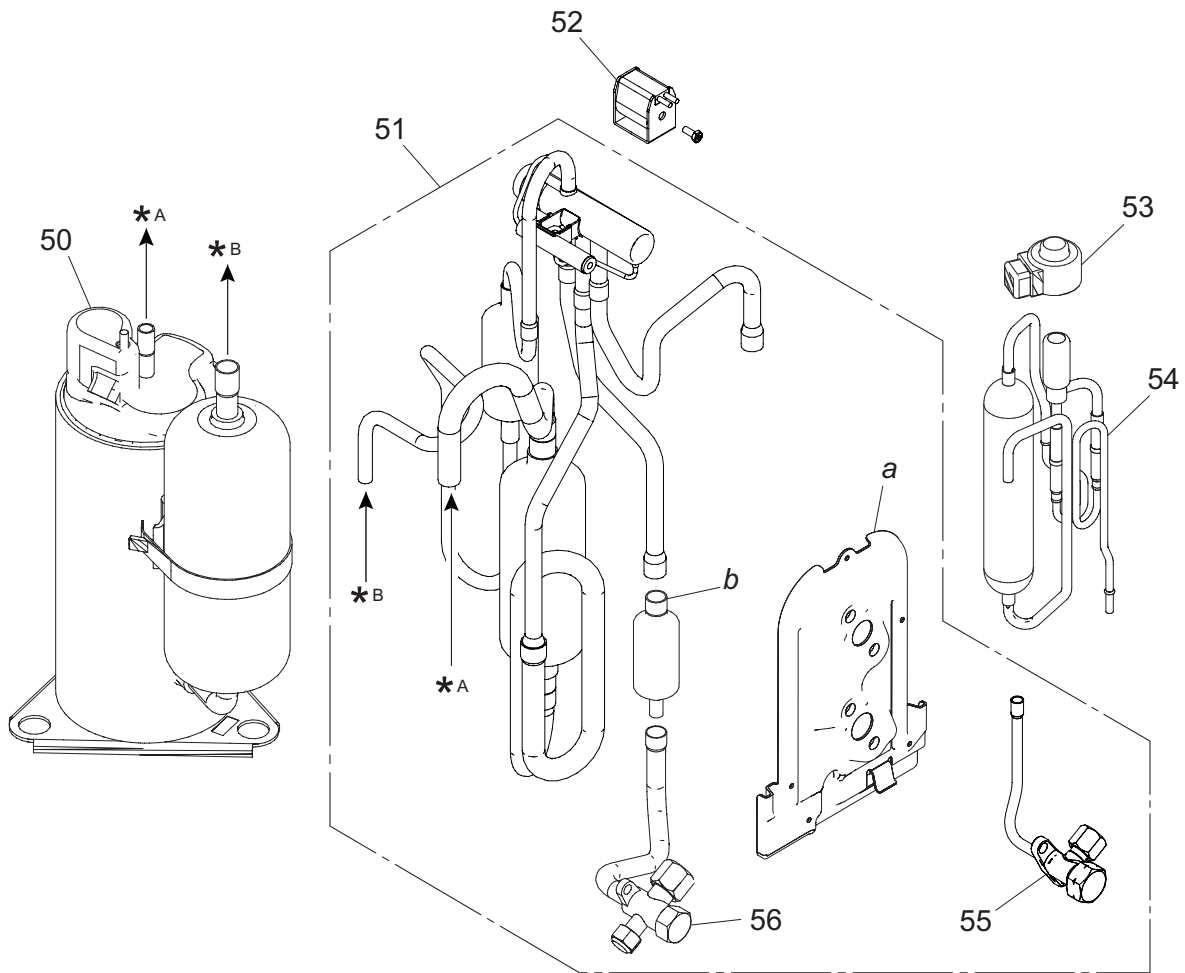

Item no.	Part no.	Part name	Service part
50	9322433008	Compressor assy	◆
51	9322445018	4-way valve assy	◆
52	9970194023	Solenoid	◆
53	9970095122	Expansion valve coil	◆
54	9322463005	Pulse motor valve assy	◆
55	9322474001	2-way valve assy	◆
56	9322475008	3-way valve assy	◆
57	9323045002	Sound insulator V	◆
58	9322537003	Sound insulator H	◆
59	9324024006	Sound insulator B	◆
60	9322847003	Sound insulator F	◆
61	9322386007	Cushion rubber	◆
62	9313437008	Nut special assy	◆
—	9901059025	Base pan heater	◆
—	9900934040	Wire with connector (Fuse holder)	◆
<i>a</i>	—	Valve bracket	—
<i>b</i>	—	Muffler	—

### 3-3. Model: AOYG14KMCDN

#### ■ Exterior parts and chassis

TECHNICAL DATA  
AND PARTS LIST

TECHNICAL DATA  
AND PARTS LIST

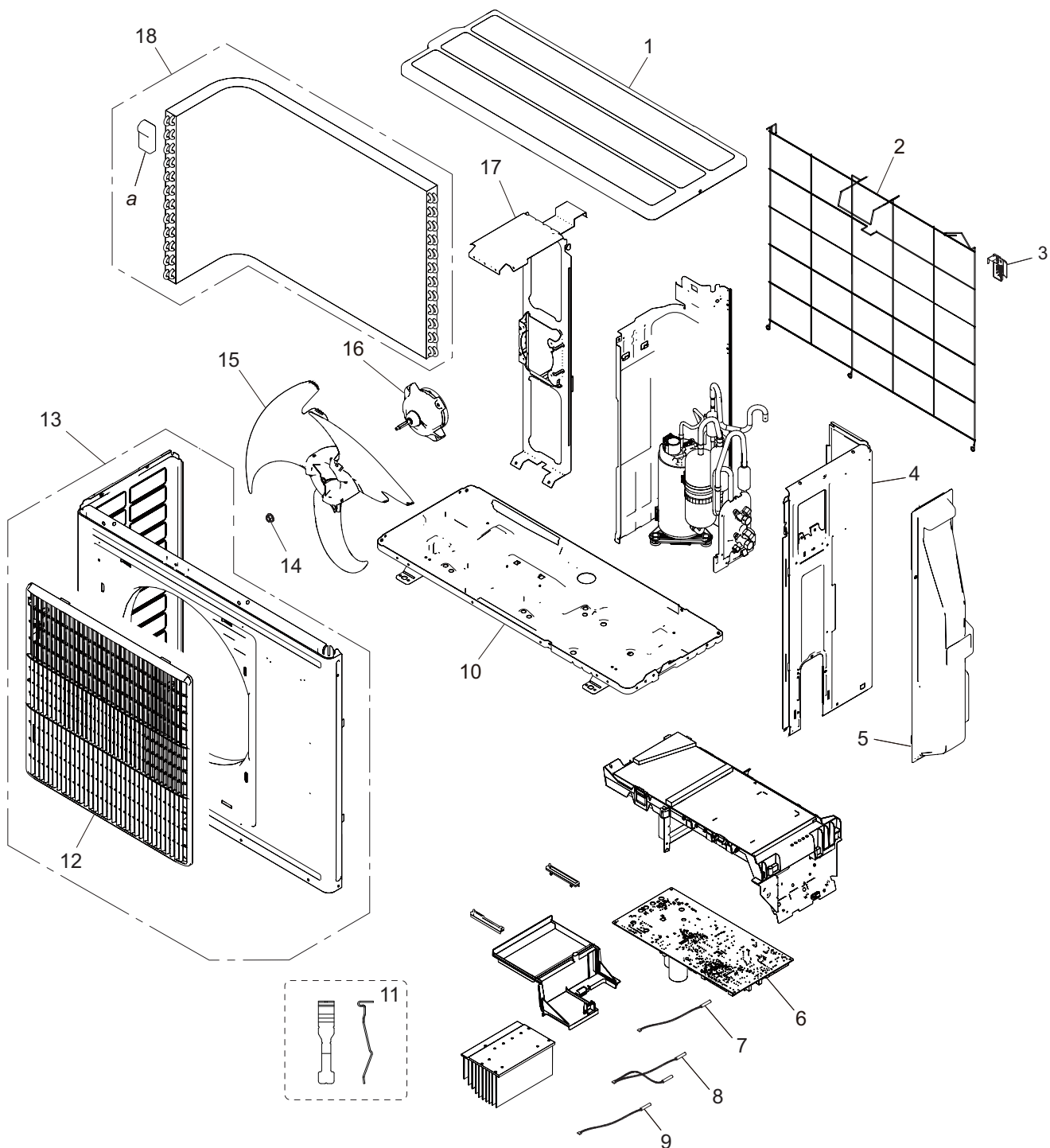

Item no.	Part no.	Part name	Service part
1	9322556073	Top panel assy	◆
2	9334053003	Protective net assy	◆
3	9322327000	Thermistor holder	◆
4	9322552082	Cabinet right assy	◆
5	9322570031	Switch cover assy	◆
6	9709685709	Main PCB (Service)	◆
7	9900850012	Thermistor (Outdoor temp.)	◆
8	9900935061	Thermistor assy	◆
9	9900985011	Compressor thermistor	◆
10	9323920002	Base assy	◆
11	9810028006	Thermistor stopper	◆
12	9384273017	Fan guard	◆
13	9322555304	Front panel assy	◆
14	0700103070	Nut	◆
15	9322150004	Propeller fan	◆
16	9603601003	DC fan motor	◆
17	9322553218	Motor bracket assy	◆
18	9323834118	Heat exchanger unit	◆
<i>a</i>	—	Hair pin cushion	—

# Compressor

TECHNICAL DATA  
AND PARTS LIST

TECHNICAL DATA  
AND PARTS LIST

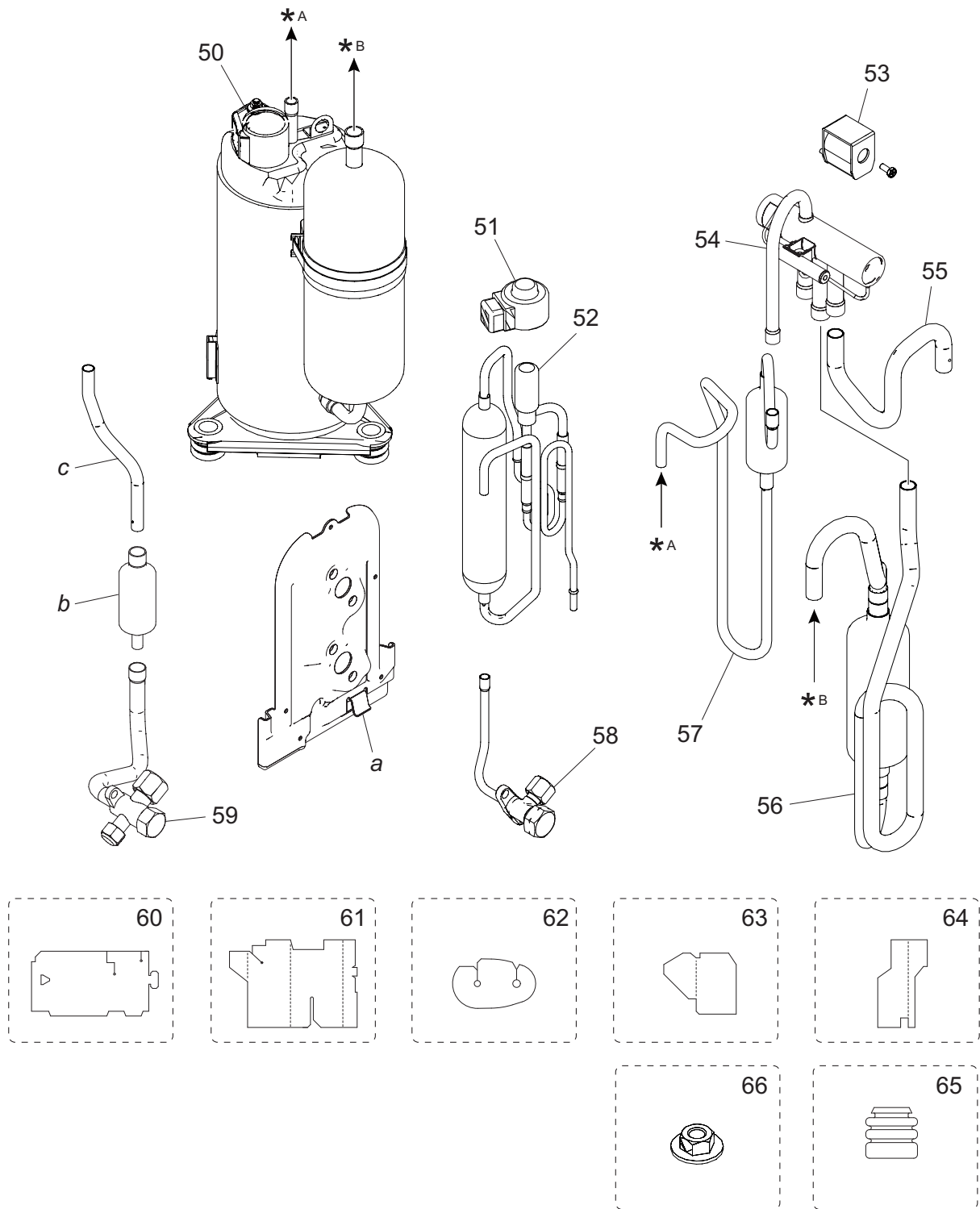





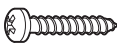

Item no.	Part no.	Part name	Service part
50	9810521002	Compressor	◆
51	9970095122	Expansion valve coil	◆
52	9322462008	Pulse motor valve assy	◆
53	9970194023	Solenoid	◆
54	9970205002	4-way valve	◆
55	9322459008	Joint pipe (Condenser)	◆
56	9322791009	Suction pipe assy	◆
57	9383949036	Discharge pipe assy	◆
58	9322474001	2-way valve assy	◆
59	9322850010	3-way valve assy	◆
60	9324014014	Sound insulator B	◆
61	9322529008	Sound insulator F	◆
62	9322501004	Sound insulator H	◆
63	9323045002	Sound insulator V	◆
64	9322824004	Sound insulator K	◆
65	9322386007	Cushion rubber	◆
66	9313437008	Nut special assy	◆
—	9900350017	Base pan heater	◆
—	9900934040	Wire with connector (Fuse holder)	◆
—	9900186029	Pressure switch	◆
—	9710542015	Wire assy (Pressure switch)	◆
<i>a</i>	—	Valve bracket	—
<i>b</i>	—	Muffler	—
<i>c</i>	—	Joint pipe (3-way valve)	—

## 4. Accessories

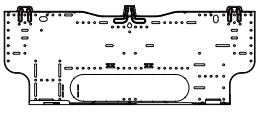
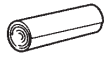
### 4-1. Indoor unit

#### ■ Models: ASYG09KMCDN, ASYG12KMCDN, and ASYG14KMCDN

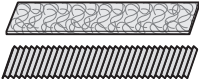
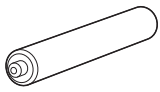
Part name	Exterior	Q'ty	Part name	Exterior	Q'ty
Operating manual		1	Tapping screw (large)		5
Installation manual		1	Tapping screw (small)		2
Wall hook bracket		1	Cloth tape		1
Remote controller		1	Filter holder		2
Remote controller holder		1	Air cleaning filters		1
Battery		2			

### 4-2. Outdoor unit

#### ■ Models: AOYG09KMCDN, AOYG12KMCDN, and AOYG14KMCDN



Part name	Exterior	Qty	Part name	Exterior	Qty
Installation manual		1			



## 5. Optional parts

### 5-1. Indoor unit

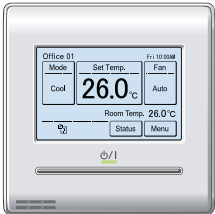
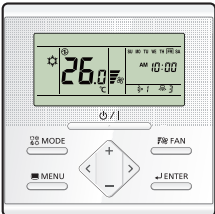



#### ■ Controllers

Exterior	Part name	Model name	Summary
	Wired Remote Controller	UTU-RNRYZ*	Easy finger touch operation with LCD panel. Backlit LCD enables easy operation in a dark room. Wire type: Non-polar 2-wire Optional Communication Kit is necessary for installation.
	Wired Remote Controller	UTU-RLRY	High visibility and easy operation. Room temperature can be accurately controlled using the thermo sensor. Wire type: Non-polar 2-wire Optional Communication Kit is necessary for installation.
	Simple Remote Controller	UTU-RSRY	Compact remote controller concentrates on the basic functions such as Start/Stop, fan control, temperature setting, and operation mode. Wire type: Non-polar 2-wire Optional Communication Kit is necessary for installation.
	Simple Remote Controller	UTU-RHRY	Compact remote controller concentrates on the basic functions such as Start/Stop, fan control, and temperature setting. Wire type: Non-polar 2-wire Optional Communication Kit is necessary for installation.

#### NOTES:

- Available functions may differ by the remote controller. For details, refer to the operation manual.
- When using the group controlling system of the Wired Remote Controller, using WLAN Adapter is prohibited.

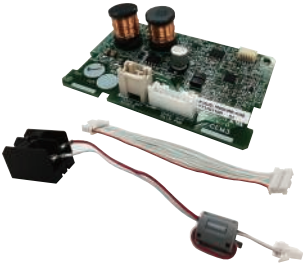
## Others

Exterior	Part name	Model name	Summary
	External Connect Kit	UTY-XWZXZ5	Required when external device is connected.
	External Input and Output PCB	UTY-XCSXZ2	Use to connect with external devices and air conditioner PCB. Optional External Connect Kit is necessary for installation.
	Communication Kit	UTY-TWRXZ2	Use to connect Non-polar 2-core wired remote controller.
	Modbus Converter	UTY-VMSX	For connection between indoor unit with UART interface and a Modbus open network.
	KNX Converter	UTY-VKSX	For connection between indoor unit with UART interface and a KNX open network.

**NOTE:** Combined use of following optional parts and WLAN Adapter is not allowed.

- External Input and Output PCB
- Modbus Converter
- KNX Converter

## 6. Refrigerant system diagrams

### 6-1. Models: AOYG09KMCDN and AOYG12KMCDN

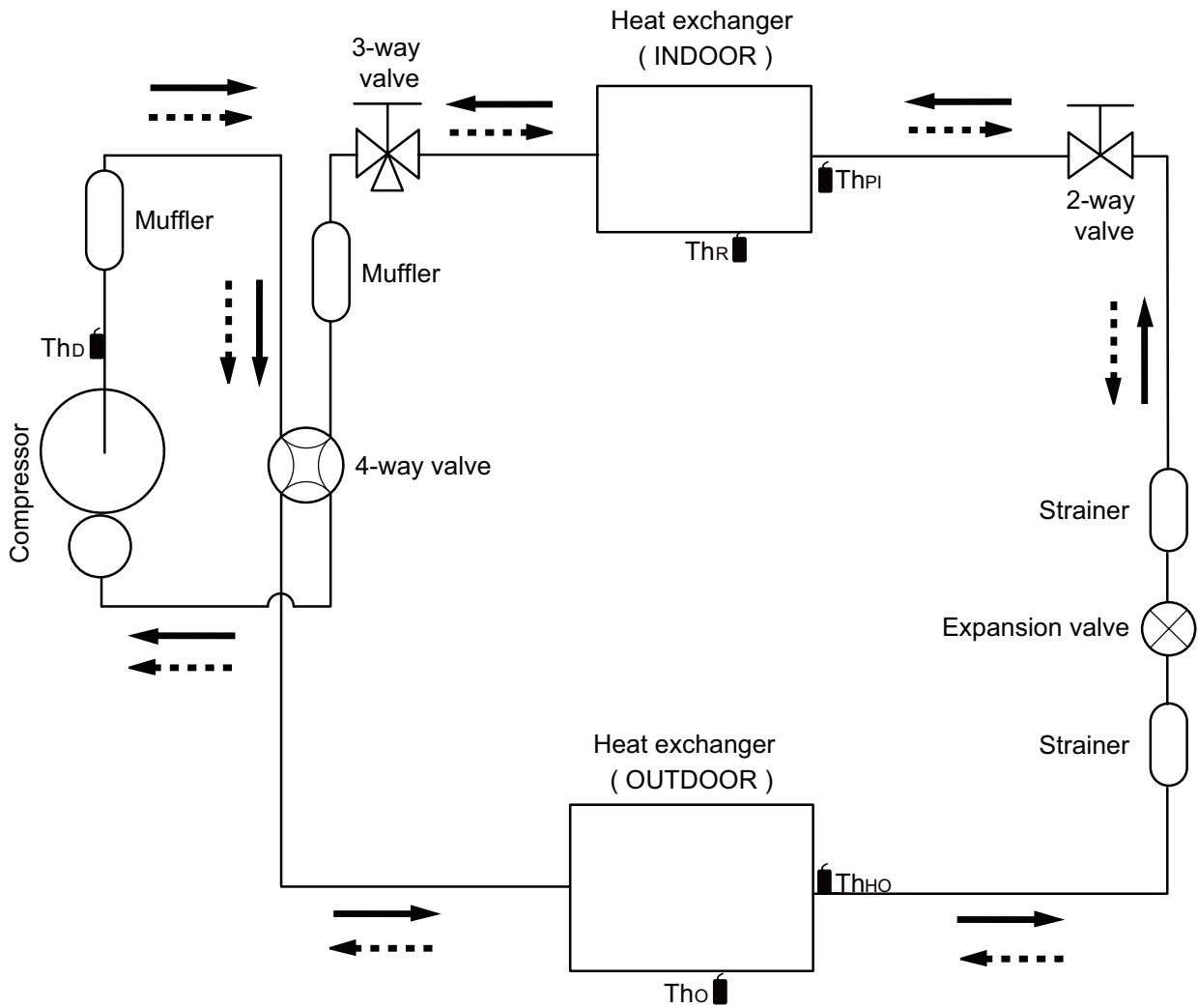

Cooling  
 Heating

Th<sub>D</sub> : Thermistor (Discharge temp.)

Th<sub>O</sub> : Thermistor (Outdoor temp.)

Th<sub>HO</sub> : Thermistor (Heat exchanger out temp.)

Th<sub>PI</sub> : Thermistor (Pipe temp.)

Th<sub>R</sub> : Thermistor (Room temp.)

# 6-2. Model: AOYG14KMCDN

TECHNICAL DATA  
AND PARTS LIST

TECHNICAL DATA  
AND PARTS LIST

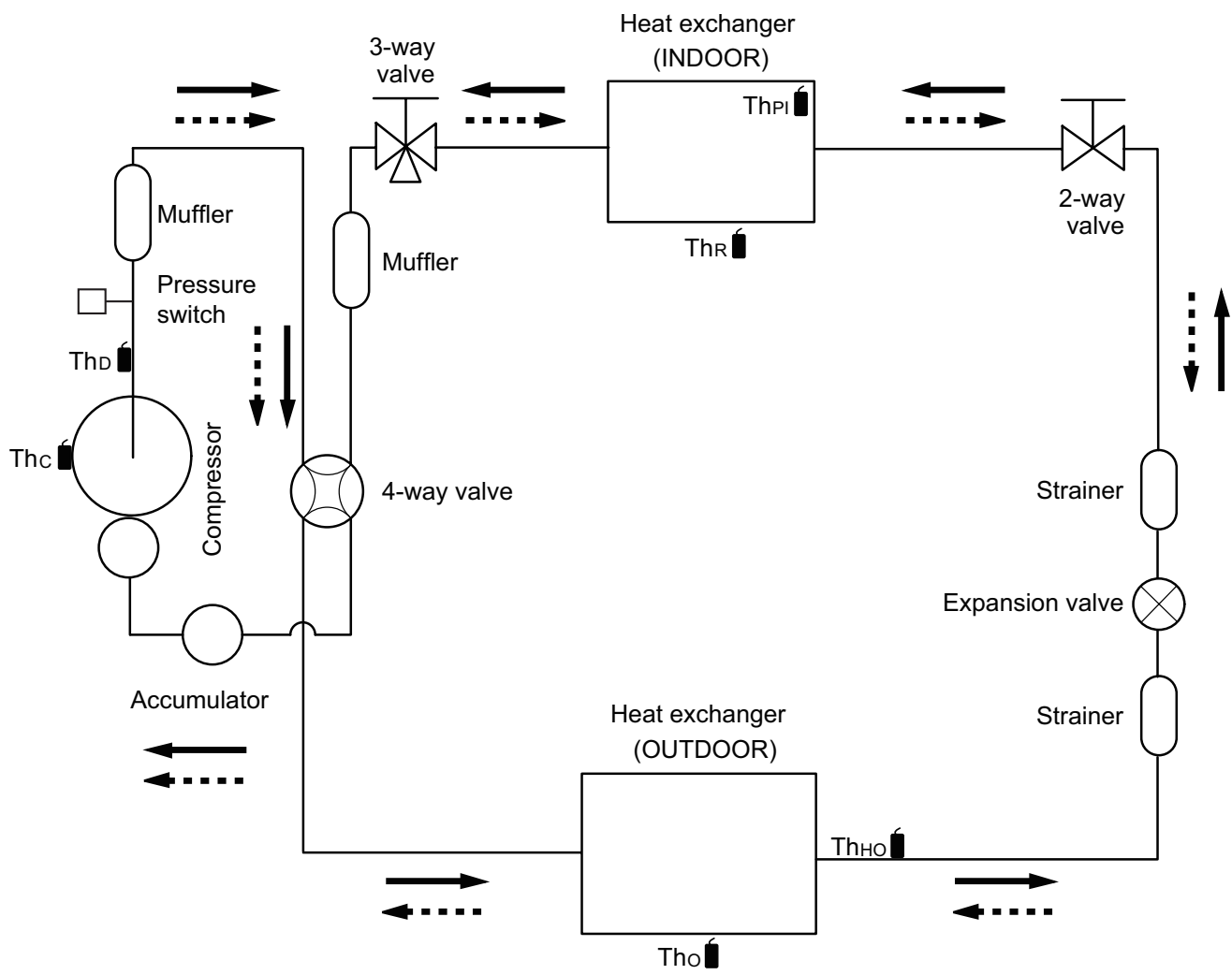

Cooling  
 Heating

- Thc : Thermistor (Compressor temperature)
- Thd : Thermistor (Discharge temperature)
- Tho : Thermistor (Outdoor temperature)
- ThHo : Thermistor (Heat exchanger out temperature)
- ThPI : Thermistor (Pipe temperature)
- ThR : Thermistor (Room temperature)

# 7. Wiring diagrams

## 7-1. Indoor unit

■ Models: ASYG09KMCDN, ASYG12KMCDN, and ASYG14KMCDN

TECHNICAL DATA  
AND PARTS LIST

TECHNICAL DATA  
AND PARTS LIST

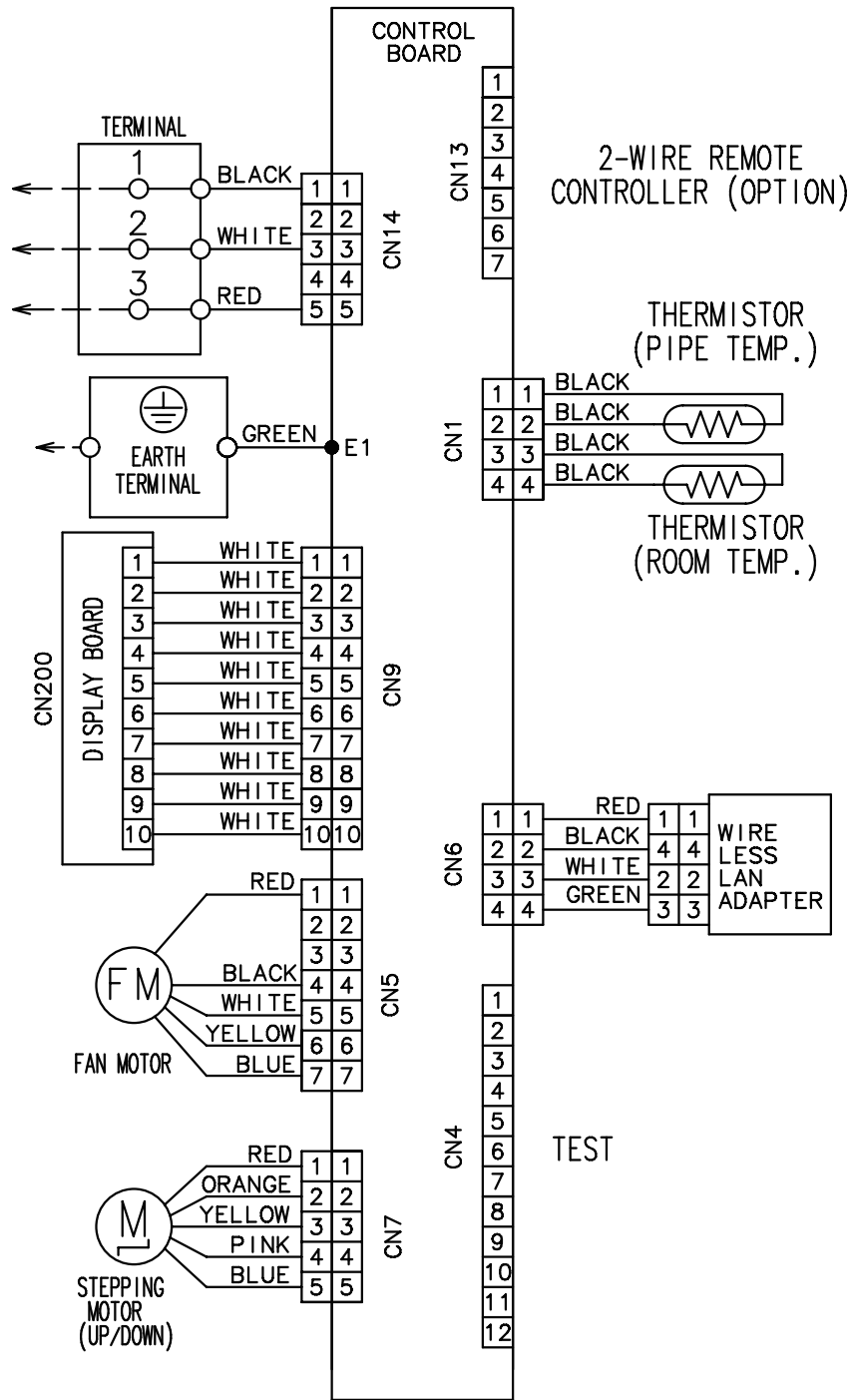

## 7-2. Outdoor unit

### Models: AOYG09KMCDN and AOYG12KMCDN

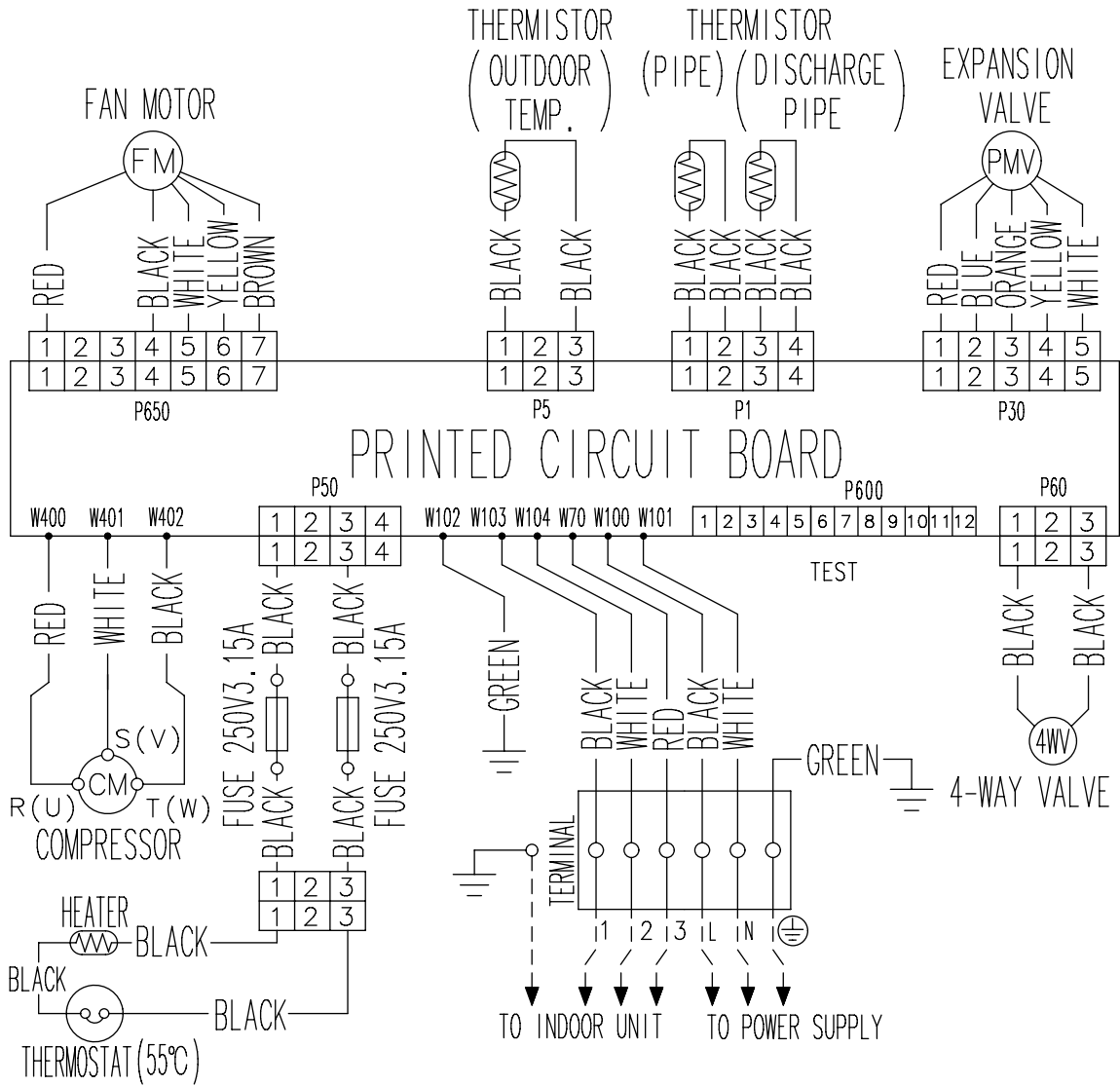

Model: AOYG14KMCDN

TECHNICAL DATA  
AND PARTS LIST

TECHNICAL DATA  
AND PARTS LIST

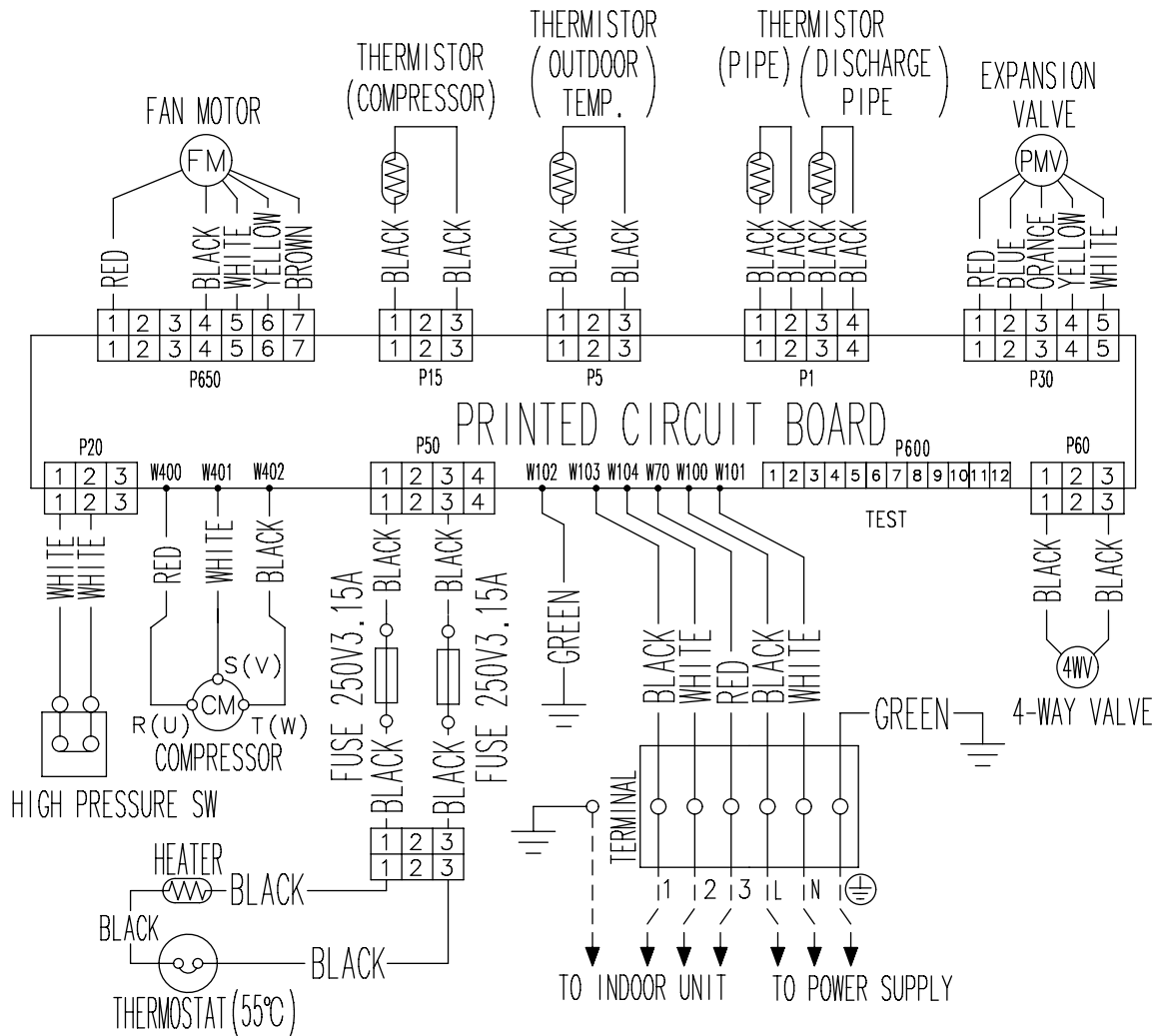

# 8. PC board diagrams

## 8-1. Models: ASYG09KMCDN, ASYG12KMCDN, and ASYG14KMCDN

CONTROL UNIT  
 09 model : EZ-020CHSE  
 12 model : EZ-020DHSE  
 14 model : EZ-020EHSE

TECHNICAL DATA AND PARTS LIST

TECHNICAL DATA AND PARTS LIST

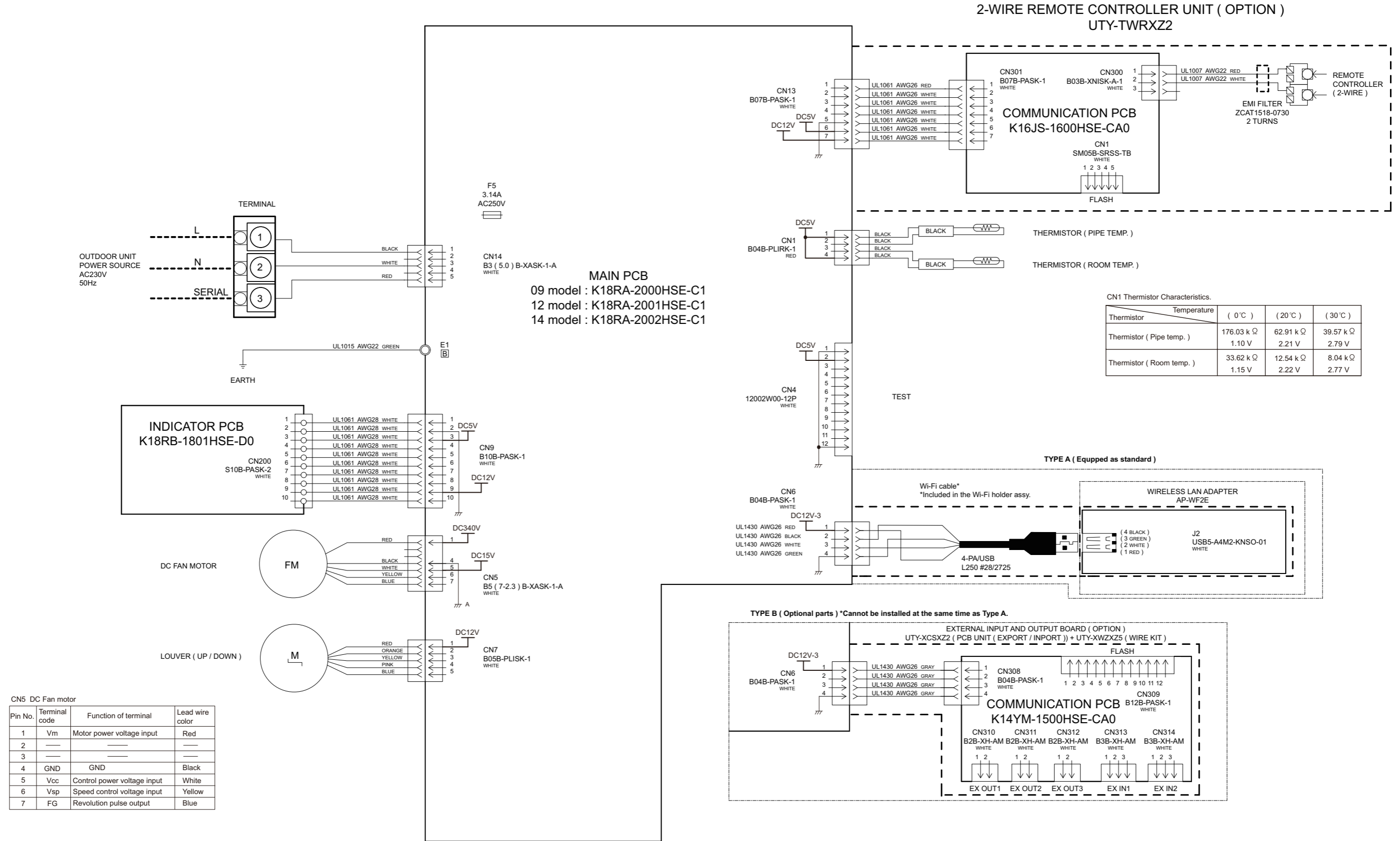



# 8-2. Models: AOYG09KMCDN and AOYG12KMCDN

INVERTER ASSEMBLY  
09,12 models : EZ-020YHUE

TECHNICAL DATA  
AND PARTS LIST

TECHNICAL DATA  
AND PARTS LIST

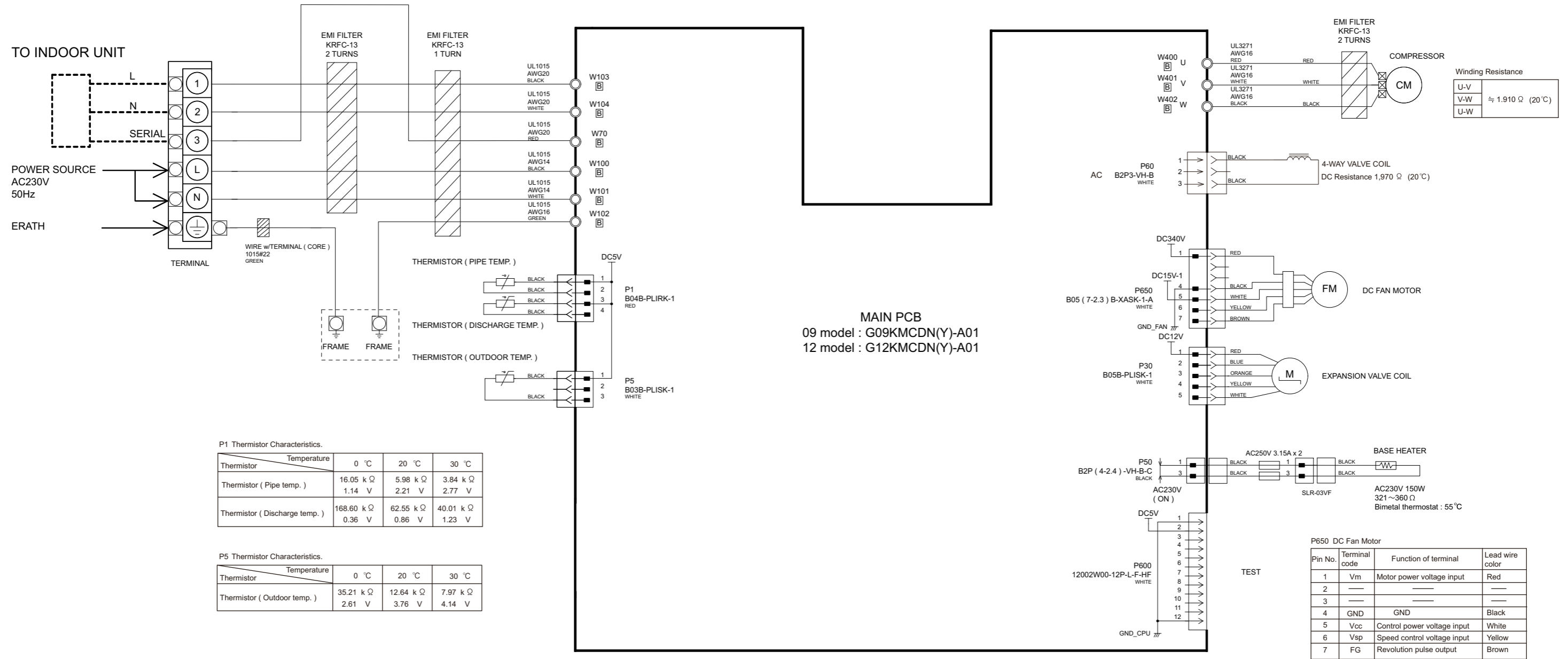

P1 Thermistor Characteristics.

Thermistor	Temperature	0 °C	20 °C	30 °C
Thermistor ( Pipe temp. )		16.05 k Ω	5.98 k Ω	3.84 k Ω
		1.14 V	2.21 V	2.77 V
Thermistor ( Discharge temp. )		168.60 k Ω	62.55 k Ω	40.01 k Ω
		0.36 V	0.86 V	1.23 V

P5 Thermistor Characteristics.

Thermistor	Temperature	0 °C	20 °C	30 °C
Thermistor ( Outdoor temp. )		35.21 k Ω	12.64 k Ω	7.97 k Ω
		2.61 V	3.76 V	4.14 V

P650 DC Fan Motor

Pin No.	Terminal code	Function of terminal	Lead wire color
1	Vm	Motor power voltage input	Red
2	—	—	—
3	—	—	—
4	GND	GND	Black
5	Vcc	Control power voltage input	White
6	Vsp	Speed control voltage input	Yellow
7	FG	Revolution pulse output	Brown

P30 Expansion Valve Coil

Recommended Drive Condition

Unipolar Drive, 1-2 Phase Excitation.

1(Red) - 3(Blue)	Coil resistance ≈ 46.0 Ω (20 °C)
1(Red) - 4(Orange)	
1(Red) - 5(Yellow)	
1(Red) - 6(White)	

# 8-3. Model: AOYG14KMCDN

INVERTER ASSEMBLY  
14 model : EZ-0200HUE

TECHNICAL DATA  
AND PARTS LIST

TECHNICAL DATA  
AND PARTS LIST

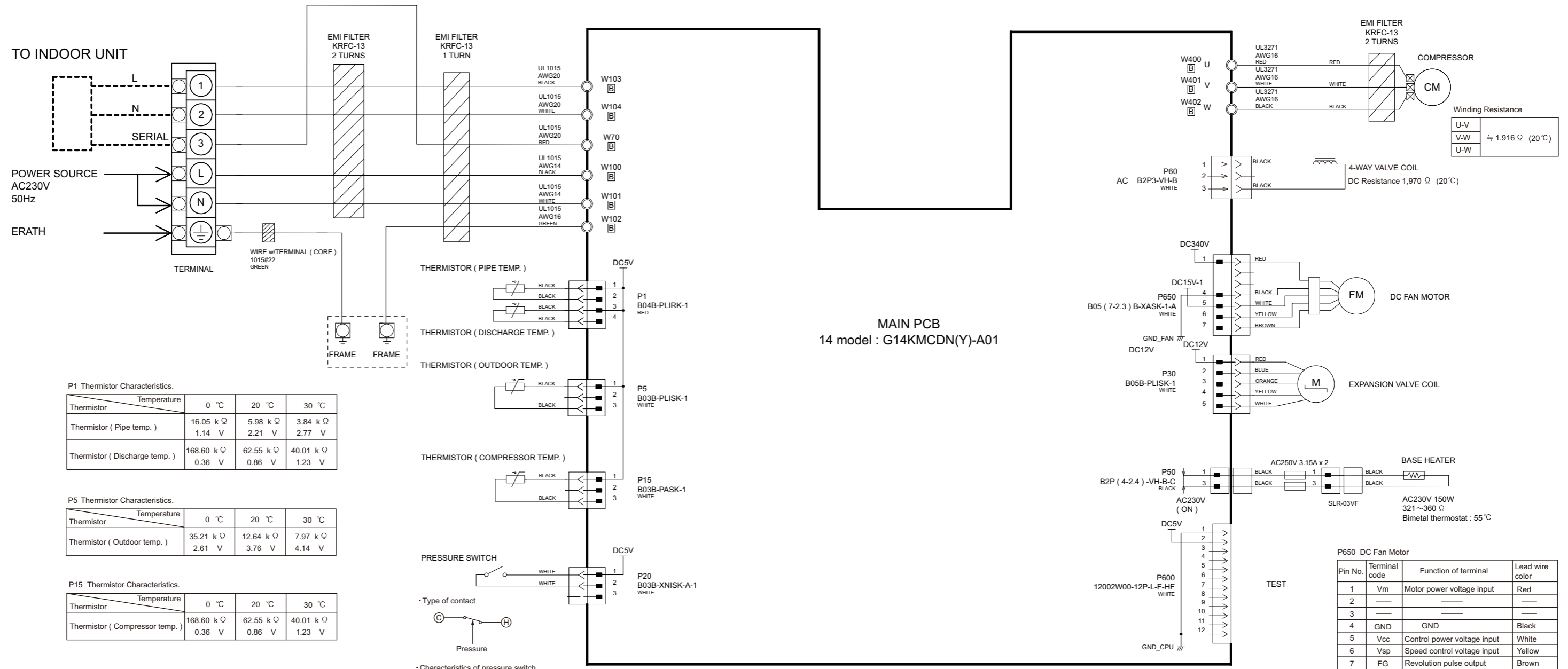

P1 Thermistor Characteristics.

Thermistor	Temperature	0 °C	20 °C	30 °C
Thermistor ( Pipe temp. )		16.05 k Ω	5.98 k Ω	3.84 k Ω
		1.14 V	2.21 V	2.77 V
Thermistor ( Discharge temp. )		168.60 k Ω	62.55 k Ω	40.01 k Ω
		0.36 V	0.86 V	1.23 V

P5 Thermistor Characteristics.

Thermistor	Temperature	0 °C	20 °C	30 °C
Thermistor ( Outdoor temp. )		35.21 k Ω	12.64 k Ω	7.97 k Ω
		2.61 V	3.76 V	4.14 V

P15 Thermistor Characteristics.

Thermistor	Temperature	0 °C	20 °C	30 °C
Thermistor ( Compressor temp. )		168.60 k Ω	62.55 k Ω	40.01 k Ω
		0.36 V	0.86 V	1.23 V

• Characteristics of pressure switch

Contact : Short ⇒ Open	4.2 ~ 4.05MPa
Contact : Open ⇒ Short	3.2±0.15MPa

P650 DC Fan Motor

Pin No.	Terminal code	Function of terminal	Lead wire color
1	Vm	Motor power voltage input	Red
2	—	—	—
3	—	—	—
4	GND	GND	Black
5	Vcc	Control power voltage input	White
6	Vsp	Speed control voltage input	Yellow
7	FG	Revolution pulse output	Brown

P30 Expansion Valve Coil  
Recommended Drive Condition  
Unipolar Drive, 1-2 Phase Excitation.

1(Red) - 3(Blue)	Coil resistance ≈ 46.0 Ω (20 °C)
1(Red) - 4(Orange)	
1(Red) - 5(Yellow)	
1(Red) - 6(White)	

## **3. TROUBLESHOOTING**

# CONTENTS

## 3. TROUBLESHOOTING

<b>1. Error code .....</b>	<b>03-1</b>
1-1. How to check the error memory.....	03-1
1-2. How to erase the error memory .....	03-1
1-3. Error code table (Indoor unit and wired remote controller).....	03-2
<b>2. Troubleshooting with error code .....</b>	<b>03-3</b>
2-1. E: 11. Serial communication error (Serial reverse transfer error) (Outdoor unit).....	03-3
2-2. E: 11. Serial communication error (Serial forward transfer error) (Indoor unit) .....	03-5
2-3. E: 12. Wired remote controller communication error (Indoor unit) .....	03-7
2-4. E: 18. External communication error (Indoor unit) .....	03-8
2-5. E: 22. Indoor unit capacity error (Indoor unit) .....	03-9
2-6. E: 23. Combination error (Outdoor unit).....	03-10
2-7. E: 32. Indoor unit main PCB error (Indoor unit) .....	03-11
2-8. E: 35. MANUAL AUTO button error (Indoor unit).....	03-12
2-9. E: 41. Room temperature sensor error (Indoor unit).....	03-13
2-10. E: 42. Indoor unit heat exchanger sensor error (Indoor unit) .....	03-14
2-11. E: 51. Indoor unit fan motor error (Indoor unit) .....	03-15
2-12. E: 62. Outdoor unit main PCB error (Outdoor unit).....	03-16
2-13. E: 64. PFC circuit error (Outdoor unit) .....	03-17
2-14. E: 65. IPM error (Outdoor unit) .....	03-18
2-15. E: 71. Discharge thermistor error (Outdoor unit).....	03-20
2-16. E: 73. Outdoor unit heat exchanger thermistor error (Outdoor unit).....	03-21
2-17. E: 74. Outdoor temperature thermistor error (Outdoor unit).....	03-22
2-18. E: 84. Current sensor error (Outdoor unit) .....	03-23
2-19. E: 94. Trip detection (Outdoor unit) .....	03-24
2-20. E: 95. Compressor motor control error (Outdoor unit) .....	03-25
2-21. E: 97. Outdoor unit fan motor error (Outdoor unit).....	03-26
2-22. E: 99. 4-way valve error (Outdoor unit).....	03-27
2-23. E: A1. Discharge temperature error (Outdoor unit).....	03-29
2-24. E: A3. Compressor temperature error (Outdoor unit) (For 14 model) .....	03-31
<b>3. Troubleshooting without error code.....</b>	<b>03-33</b>
3-1. Indoor unit—No power.....	03-33
3-2. Outdoor unit—No power .....	03-34
3-3. No operation (Power is on).....	03-35
3-4. No cooling/No heating .....	03-36
3-5. Abnormal noise.....	03-38
3-6. Water leaking.....	03-39
<b>4. Service parts information .....</b>	<b>03-40</b>
4-1. Compressor .....	03-40
4-2. Inverter compressor.....	03-41
4-3. Outdoor unit Electronic Expansion Valve (EEV) .....	03-42
4-4. Indoor unit fan motor .....	03-44

## CONTENTS (continued)

4-5. Outdoor unit fan motor .....	03-45
4-6. 4-way valve coil (solenoid coil)/4-way valve .....	03-46
<b>5. Thermistor resistance values.....</b>	<b>03-47</b>
5-1. Indoor unit .....	03-47
5-2. Outdoor unit.....	03-48



# 1. Error code

When a problem occurs in the system or the connected device, the error content is notified by displaying the code.

**NOTE:** This function is only available in a system with indoor or IR receiver units equipped with indicator lamps to show the error content.

Errors, once displayed, will be automatically stored in the PC board of the indoor unit. Even if the power is disconnected, the memory containing the error history will not be erased.

If another error occurs later, the stored error memory will be updated automatically and replaced with the new one. (Previous error will be erased.)

## 1-1. How to check the error memory

When an error occurs, the operation lamp (Green) and the timer lamp (Orange) indicate the error content by blinking. To check the error memory, follow the procedures below.

1. Stop the operation of the air conditioner, and then disconnect the power supply.
2. Reconnect the power supply.
3. In one of the following two methods, the memorized error is only displayed during the “3 minutes ST”<sup>\*</sup> state period.
  - Start the operation and then press the TEST RUN button on the remote controller.
  - Press the MANUAL AUTO button on the indoor unit for 10 seconds or more.

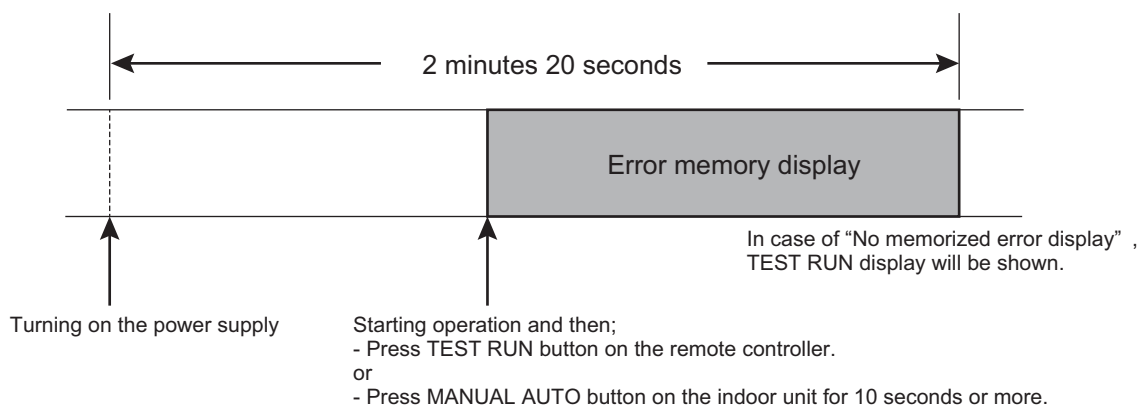

\*: The “3 minutes ST” period lasts 2 minutes and 20 seconds after turning on the power supply.

## 1-2. How to erase the error memory

The error memory can be erased in one of the following two methods.

- Manual erase: Pressing the MANUAL AUTO button on the indoor unit while the “Error memory display” is being shown. (Short beep emits for about 3 seconds.)
- Automatic erase: After continuing the normal operation of the air conditioner without error for 2 hours or longer after displaying the error memory as described in [How to check the error memory](#). (Except FAN operation mode.)

## 1-3. Error code table (Indoor unit and wired remote controller)

The operation, timer, and economy indicators operate according to the error contents.

For confirmation of the error contents, refer the flashing pattern as follows.

Error contents	Indoor unit display			Wired remote controller display
	Operation [I] (Green)	Timer [⌚] (Orange)	Economy [E] (Green)	
E: 11. Serial communication error (Serial reverse transfer error) (Outdoor unit)	1 times	1 times	Continuous	11
E: 11. Serial communication error (Serial forward transfer error) (Indoor unit)	1 times	1 times	Continuous	11
E: 12. Wired remote controller communication error (Indoor unit)	1 times	2 times	Continuous	12
E: 18. External communication error (Indoor unit)	1 times	8 times	Continuous	18
E: 22. Indoor unit capacity error (Indoor unit)	2 times	2 times	Continuous	22
E: 23. Combination error (Outdoor unit)	2 times	3 times	Continuous	23
E: 32. Indoor unit main PCB error (Indoor unit)	3 times	2 times	Continuous	32
E: 35. MANUAL AUTO button error (Indoor unit)	3 times	5 times	Continuous	35
E: 41. Room temperature sensor error (Indoor unit)	4 times	1 times	Continuous	41
E: 42. Indoor unit heat exchanger sensor error (Indoor unit)	4 times	2 times	Continuous	42
E: 51. Indoor unit fan motor error (Indoor unit)	5 times	1 times	Continuous	51
E: 62. Outdoor unit main PCB error (Outdoor unit)	6 times	2 times	Continuous	62
E: 64. PFC circuit error (Outdoor unit)	6 times	4 times	Continuous	64
E: 65. IPM error (Outdoor unit)	6 times	5 times	Continuous	65
E: 71. Discharge thermistor error (Outdoor unit)	7 times	1 times	Continuous	71
E: 73. Outdoor unit heat exchanger thermistor error (Outdoor unit)	7 times	3 times	Continuous	73
E: 74. Outdoor temperature thermistor error (Outdoor unit)	7 times	4 times	Continuous	74
E: 84. Current sensor error (Outdoor unit)	8 times	4 times	Continuous	84
E: 94. Trip detection (Outdoor unit)	9 times	4 times	Continuous	94
E: 95. Compressor motor control error (Outdoor unit)	9 times	5 times	Continuous	95
E: 97. Outdoor unit fan motor error (Outdoor unit)	9 times	7 times	Continuous	97
E: 99. 4-way valve error (Outdoor unit)	9 times	9 times	Continuous	99
E: A1. Discharge temperature error (Outdoor unit)	10 times	1 times	Continuous	A1
E: A3. Compressor temperature error (Outdoor unit) (For 14 model)	10 times	3 times	Continuous	A3



## 2. Troubleshooting with error code

### 2-1. E: 11. Serial communication error (Serial reverse transfer error) (Outdoor unit)

Indicator	Indoor unit	Operation indicator	1 time flash
		Timer indicator	1 time flash
		Economy indicator	Continuous flash
		Error code	E: 11
Detective actuator	Outdoor unit	Main PCB	When the indoor unit cannot receive the serial signal from outdoor unit more than 2 minutes after power on, or the indoor unit cannot receive the serial signal more than 15 seconds during normal operation.
		Fan motor	
Forecast of cause		Connection failure	
		External cause	
		Main PCB failure	
		Outdoor unit fan motor failure	

Check point 1. Reset the power and operate

Does error indication show again?

→ If no, go to "Check point 1-2".



Check point 2. Check connection

Check any loose or removed connection line of indoor unit and outdoor unit.

Check connection condition is control unit. (If there is loose connector, open cable or mis-wiring.)

→ If there is an abnormal condition, correct it by referring to the installation manual or the "DESIGN & TECHNICAL MANUAL".



Check point 3. Check the voltage of power supply

Check the voltage of power supply

Check if AC 207 (AC 230 V -10%) to AC 253 V (AC 230 V +10%) appears at outdoor unit terminal L — N.

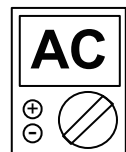

## Check point 4. Check serial signal (Reverse transfer signal)

## Check serial signal (Reverse transfer signal)

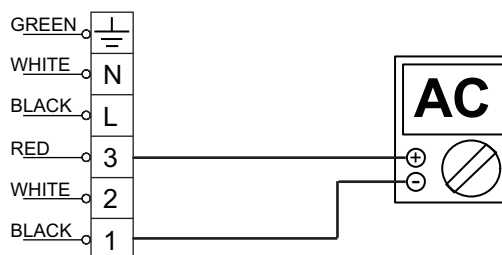

- Check if indicated value swings between AC 90 V and AC 270 V at the outdoor unit terminal 1—3.
- If it is abnormal, check the parts below.
  - Outdoor unit fan motor in "[Service parts information](#)" on page 03-40
- If outdoor fan motor is abnormal, replace outdoor unit fan motor and main PCB.
- If the checked parts are normal, replace the main PCB.



**End**

## Check point 1-2. Check external cause such as noise

- Check the complete insulation of the grounding.
- Check if there is any equipment that causes harmonic wave near the power cable (Neon light bulb or any electronic equipment which causes harmonic wave).



**End**

## 2-2. E: 11. Serial communication error (Serial forward transfer error) (Indoor unit)

Indicator	Indoor unit	Operation indicator	1 time flash
		Timer indicator	1 time flash
		Economy indicator	Continuous flash
		Error code	E: 11
Detective actuator	Indoor unit	Main PCB	When the outdoor unit cannot properly receive the serial signal from indoor unit for 10 seconds or more.
		Fan motor	
	Outdoor unit	Main PCB	
Forecast of cause			Connection failure
			External cause
			Main PCB failure

### Check point 1. Reset the power and operate

Does error indication show again?

→ If no, go to "Check point 1-2".



### Check point 2. Check connection

Check any loose or removed connection line of indoor unit and outdoor unit.

→ If there is an abnormal condition, correct it by referring to the installation manual or the "DESIGN & TECHNICAL MANUAL".

Check connection condition is control unit. (If there is loose connector, open cable or mis-wiring.)



### Check point 3. Check the voltage of power supply

Check the voltage of power supply

Check if AC 207 (AC 230 V -10%) to AC 253 V (AC 230 V +10%) appears at outdoor unit terminal L — N.



## Check point 4. Check serial signal (Forward transfer signal)

## Check serial signal (Forward transfer signal)

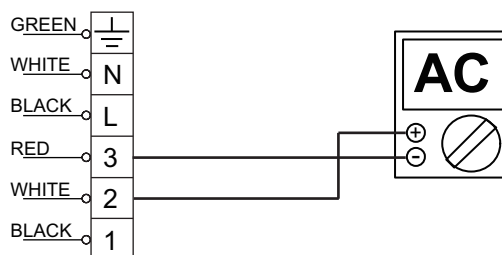

- Check if indicated value swings between AC 30 V and AC 130 V at outdoor unit terminal 2—3.
- If it is abnormal, replace main PCB.



**End**

## Check point 1-2. Check external cause such as noise

- Check if the ground connection is proper.
- Check if there is any equipment that causes harmonic wave near the power cable (Neon light bulb or any electronic equipment which causes harmonic wave).



**End**

## 2-3. E: 12. Wired remote controller communication error (Indoor unit)

Indicator	Indoor unit	Operation indicator	1 time flash
		Timer indicator	2 time flash
		Economy indicator	Continuous flash
		Error code	E: 12
Detective actuator	Indoor unit	Main PCB	When the indoor unit cannot receive the signal from Wired remote controller more than 1 minute during normal operation.
	Wired remote control		
Forecast of cause			Terminal connection abnormal
			Wired remote control failure
			Main PCB failure

### Check point 1. Check the connection of terminal

After turning off the power, check & correct the followings.

- Check the connection of terminal between remote controller and indoor unit, and check if there is a disconnection of the cable.



### Check point 2. Check connection

Check voltage at CNC01 (terminal 1—3) of UTY-TWBXF (Communication kit). (Power supply to the remote controller)

Upon correcting the removed connector or mis-wiring, reset the power.



- If it is DC 12 V, remote controller is failure. (Main PCB is normal)
  - Replace Remote Control
- If it is DC 0 V, main PCB is failure. (Check remote controller once again)
  - Replace main PCB



**End**

## 2-4. E: 18. External communication error (Indoor unit)

Indicator	Indoor unit	Operation indicator	1 time flash
		Timer indicator	8 time flash
		Economy indicator	Continuous flash
		Error code	E: 18
Detective actuator	Indoor unit	External communication error	After receiving a signal from the external input and output PCB, the same signal has not been received for 15 seconds.
Forecast of cause			Connection failure
			WLAN adapter failure
			Main PCB

### Check point 1. Check the connection

- Check any loose or removed connection between the main PCB to the WLAN adapter.  
-> If there is an abnormal condition, correct it by refer to the installation manual or the "DESIGN & TECHNICAL MANUAL".
- Check the connection condition on the WLAN adapter and the main PCB (If there is loose connector, open cable or mis-wiring.)



### Check point 2. Replace the WLAN adapter

If check point 1 do not improve the symptom, change WLAN adapter.



### Check point 3. Replace the main PCB

If check point 2 do not improve the symptom, replace the main PCB.



**End**

## 2-5. E: 22. Indoor unit capacity error (Indoor unit)

Indicator	Indoor unit	Operation indicator	2 time flash
		Timer indicator	2 time flash
		Economy indicator	Continuous flash
		Error code	E: 22
Detective actuator	Indoor unit main PCB	When the total capacity of the indoor units does not match outdoor unit capacity while 3 minutes after power on.	
Forecast of cause		Indoor unit selection is incorrect.	
		Main PCB failure	

### Check point 1. Check the total capacity of indoor units

Check the total capacity of the indoor units.

→ If abnormal condition is found, correct it referring to the installation manual or DESIGN & TECHNICAL MANUAL.



### Check point 2. Replace the main PCB

If check point 1 does not improve the symptom, replace the main PCB.



**End**

## 2-6. E: 23. Combination error (Outdoor unit)

Indicator	Indoor unit	Operation indicator	2 time flash
		Timer indicator	3 time flash
		Economy indicator	Continuous flash
		Error code	E: 23
Detective actuator	Indoor unit	The outdoor unit receives the serial signal of applied refrigerant information from indoor unit.	
Forecast of cause		Incorrect indoor unit is selected.	

### Check point 1. Check the type of indoor unit

- Check the type of the connected indoor unit.  
-> If there is an abnormal condition, correct it by refer to the installation manual or the "DESIGN & TECHNICAL MANAL".



### Check point 2. Replace the main PCB

If check point 1 do not improve the symptom, replace the main PCB of the outdoor unit.



**End**



## 2-7. E: 32. Indoor unit main PCB error (Indoor unit)

Indicator	Indoor unit	Operation indicator	3 time flash
		Timer indicator	2 time flash
		Economy indicator	Continuous flash
		Error code	E: 32
Detective actuator	Indoor unit	main PCB	When power is on and there is some below case. 1. When model information of EEPROM is incorrect. 2. When the access to EEPROM failed.
Forecast of cause			External cause
			Defective connection of electrical components
			Main PCB failure

Check point 1. Reset power supply and operate

Does error indication show again?

→ If no, go to "Check point 1-2".



Check point 2. Check Indoor unit electrical components

- Check all connectors. (loose connector or incorrect wiring)
- Check any shortage or corrosion on PCB.



Check point 3. Replace the main PCB

Replace the main PCB.



**End**

Check point 1-2. Check external cause such as noise

- Check if the ground connection is proper.
- Check if there is any equipment that causes harmonic wave near the power cable (Neon light bulb or any electronic equipment which causes harmonic wave).



**End**

### NOTE: EEPROM

EEPROM (Electrically Erasable and Programmable Read Only Memory) is a non-volatile memory which keeps memorized information even if the power is turned off. It can change the contents electronically. To change the contents, it uses higher voltage than normal, and it cannot change a partial contents. (Rewriting shall be done upon erasing the all contents.) There is a limit in a number of rewriting.

## 2-8. E: 35. MANUAL AUTO button error (Indoor unit)

Indicator	Indoor unit	Operation indicator	3 time flash
		Timer indicator	5 time flash
		Economy indicator	Continuous flash
		Error code	E: 35
Detective actuator	Indoor unit controller PCB	When the MANUAL AUTO button becomes on for consecutive 60 or more seconds.	
	Indicator PCB		
	Manual auto switch		
Forecast of cause		MANUAL AUTO button failure	
		Controller PCB and indicator PCB failure	

Check point 1. Check the MANUAL AUTO button

- Check if MANUAL AUTO button is kept pressed.
- Check ON/OFF switching operation by using a meter.

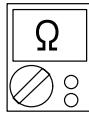

If MANUAL AUTO button is disabled (ON/OFF switching), replace it.



Check point 2. Replace the main PCB and indicator PCB

If Check Point 1 does not improve the symptom, replace the main PCB and indicator PCB.



**End**

## 2-9. E: 41. Room temperature sensor error (Indoor unit)

Indicator	Indoor unit	Operation indicator	4 time flash
		Timer indicator	1 time flash
		Economy indicator	Continuous flash
		Error code	E: 41
Detective actuator	Indoor unit main PCB	Room temperature thermistor is open or short is detected always.	
	Room temperature thermistor		
Forecast of cause		Connector failure	
		Thermistor failure	
		Main PCB failure	

### Check point 1. Check connection of connector

- Check if connector is loose or removed.
- Check erroneous connection.
- Check if thermistor cable is open

-> Reset power when reinstalling due to removed connector or incorrect wiring.



### Check point 2. Remove connector and check thermistor resistance value

- For the room thermistor resistance value, refer to "[Thermistor resistance values](#)" on page 03-47.
- If thermistor is either open or shorted, replace it and reset the power.

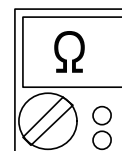

### Check point 3. Check voltage of main PCB

Make sure circuit diagram of each indoor unit and check terminal voltage at thermistor (DC 5.0 V).

**NOTE:** For details of thermistor connector, refer to "[Wiring diagrams](#)" in Chapter 2. TECHNICAL DATA AND PARTS LIST on page 02-21.  
(09-14 models: CN1)

If the voltage does not appear, replace main PCB.



**End**

## 2-10. E: 42. Indoor unit heat exchanger sensor error (Indoor unit)

Indicator	Indoor unit	Operation indicator	4 time flash
		Timer indicator	2 time flash
		Economy indicator	Continuous flash
		Error code	E: 42
Detective actuator	Indoor unit main PCB	When heat exchanger temperature thermistor open or short circuit is detected.	
	Heat exchanger temperature thermistor		
Forecast of cause			Connector connection failure
			Thermistor failure
			Main PCB failure

### Check point 1. Check connection of connector

- Check if connector is loose or removed.
- Check erroneous connection.
- Check if thermistor cable is open

-> Reset power when reinstalling due to removed connector or incorrect wiring.



### Check point 2. Remove connector and check thermistor resistance value

- For the heat exchanger thermistor resistance value, refer to "[Thermistor resistance values](#)" on page 03-47.
- If thermistor is either open or shorted, replace it and reset the power.



### Check point 3. Check voltage of main PCB

Make sure circuit diagram of each indoor unit and check terminal voltage at thermistor (DC 5.0 V).

**NOTE:** For details of thermistor connector, refer to "[Wiring diagrams](#)" in Chapter 2. TECHNICAL DATA AND PARTS LIST on page 02-21.

(09-14 models: CN1)

If the voltage does not appear, replace main PCB.



**End**

## 2-11. E: 51. Indoor unit fan motor error (Indoor unit)

Indicator	Indoor unit	Operation indicator	5 time flash
		Timer indicator	1 time flash
		Economy indicator	Continuous flash
		Error code	E: 51
Detective actuator	Indoor unit	main PCB	When the actual rotation number of the indoor unit fan motor is below 1/3 of the target rotation number continuously for more than 56 seconds.
		Fan motor	
Forecast of cause		Fan rotation failure	
		Fan motor winding open	
		Motor protection by surrounding temperature rise	
		Control PCB failure	
		Indoor unit fan motor failure	

### Check point 1. Check rotation of fan

Rotate the fan by hand when operation is off. (Check if fan is caught, dropped off or locked motor)  
→ If fan or bearing is abnormal, replace it.



### Check point 2. Check ambient temperature around motor

Check excessively high temperature around the motor. (If there is any surrounding equipment that causes heat)  
→ Upon the temperature coming down, restart operation.



### Check point 3. Check indoor unit fan motor

Check Indoor unit fan motor. (Refer to indoor unit fan motor in "[Service parts information](#)" on page 03-40.)  
→ If Indoor unit fan motor is abnormal, replace Indoor unit fan motor.



### Check point 4. Replace the main PCB

If Check Point 1 to 3 do not improve the symptom, replace the main PCB.



**End**

## 2-12. E: 62. Outdoor unit main PCB error (Outdoor unit)

Indicator	Indoor unit	Operation indicator	6 time flash
		Timer indicator	2 time flash
		Economy indicator	Continuous flash
		Error code	E: 62
Detective actuator	Outdoor unit	Main PCB	Access to EEPROM failed due to some cause after outdoor unit started.
Forecast of cause			External cause (Noise, temporary open, voltage drop)
			Main PCB failure

Check point 1. Reset power supply and operate

Does error indication show again?

If no, go to "Check point 1-2".



Check point 2. Replace the main PCB

Replace the main PCB.



**End**

Check point 1-2. Check external cause

- Check if temporary voltage drop was not generated.
- Check if momentary open was not generated.
- Check if ground is connection correctly or there are no related cables near the power line.



**End**

## 2-13. E: 64. PFC circuit error (Outdoor unit)

Indicator	Indoor unit	Operation indicator	6 time flash
		Timer indicator	4 time flash
		Economy indicator	Continuous flash
		Error code	E: 64
Detective actuator	Outdoor unit	Main PCB	<ul style="list-style-type: none"> <li>When inverter input DC voltage is higher than 415 V for over 3 seconds, the compressor stops.</li> <li>If the same operation is repeated 5 times, the compressor stops permanently.</li> </ul>
Forecast of cause			External cause
			Connector connection failure
			Main PCB failure

### Check point 1. Check external cause at indoor and outdoor (Voltage drop or Noise)

- Instant drop: Check if there is a large load electric apparatus in the same circuit.
- Momentary power failure: Check if there is a defective contact or leak current in the power supply circuit.
- Noise: Check if there is any equipment causing harmonic wave near electric line. (Neon bulb or electric equipment that may cause harmonic wave)  
Check the complete insulation of grounding.



### Check point 2. Check connection of Connector

- Check if connector is removed.
- Check erroneous connection.
- Check if cable is open.

→ Upon correcting the removed connector or mis-wiring, reset the power.



### Check point 3. Replace the main PCB

If check point 1 to 2 do not improve the symptom, replace the main PCB.



**End**

## 2-14. E: 65. IPM error (Outdoor unit)

Indicator	Indoor unit	Operation indicator	6 time flash
		Timer indicator	5 time flash
		Economy indicator	Continuous flash
		Error code	E: 65
Detective actuator	Outdoor unit	Main PCB	<ol style="list-style-type: none"> <li>1. When more than normal operating current to IPM in main PCB flows, the compressor stops.</li> <li>2. After the compressor restarts, if the same operation is repeated within 40 seconds, the compressor stops again.</li> <li>3. If 1. and 2. repeats 5 times, the compressor stops permanently.</li> </ol>
		Compressor	
Forecast of cause		<ul style="list-style-type: none"> <li>Defective connection of electrical components</li> <li>Outdoor fan operation failure</li> <li>Outdoor heat exchanger clogged</li> <li>Compressor failure</li> <li>Main PCB failure</li> </ul>	

### Check point 1. Check connections of outdoor unit electrical components

- Check if the terminal connection is loose.
- Check if connector is removed.
- Check erroneous connection.
- Check if cable is open.

→ Upon correcting the removed connector or mis-wiring, reset the power.



### Check point 2. Check outdoor fan and heat exchanger

- Is there anything obstructing the air distribution circuit?
- Is there any clogging of outdoor heat exchanger?
- Is the fan rotating by hand when operation is off?

→ If the fan motor is locked, replace it.



### Check point 3. Check outdoor fan

Check outdoor fan motor. (Refer to "[E: 97. Outdoor unit fan motor error \(Outdoor unit\)](#)" on page 03-26.)

→ If the fan motor is failure, replace it.





Check point 4. Check compressor

Check compressor. (Refer to inverter compressor in "[Service parts information](#)".)



Check point 5. Replace main PCB

If Check point 1 to 4 do not improve the symptom, change main PCB.



**End**

## 2-15. E: 71. Discharge thermistor error (Outdoor unit)

Indicator	Indoor unit	Operation indicator	7 time flash
		Timer indicator	1 time flash
		Economy indicator	Continuous flash
		Error code	E: 71
Detective actuator	Outdoor unit main PCB	When discharge pipe temperature thermistor open or short circuit is detected at power on or while running the compressor	
	Discharge pipe temperature thermistor		
Forecast of cause		Connector failure	
		Thermistor failure	
		Main PCB failure	

### Check point 1. Check connection of connector

- Check if connector is loose or removed.
- Check erroneous connection.
- Check if thermistor cable is open

→ Reset power when reinstalling due to removed connector or incorrect wiring.



### Check point 2. Remove connector and check thermistor resistance value

- For the discharge temperature thermistor resistance value, refer to "[Thermistor resistance values](#)" on page 03-47.
- If thermistor is either open or shorted, replace it and reset the power.

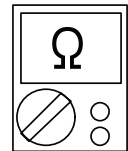

### Check point 3. Check voltage of main PCB

Make sure circuit diagram of outdoor unit and check terminal voltage at thermistor (DC 5.0 V).

**NOTE:** For details of thermistor connector, refer to "[Wiring diagrams](#)" in Chapter 2. TECHNICAL DATA AND PARTS LIST on page 02-21.

(09-14 models: P1)

If the voltage does not appear, replace main PCB.

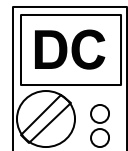

**End**

## 2-16. E: 73. Outdoor unit heat exchanger thermistor error (Outdoor unit)

Indicator	Indoor unit	Operation indicator	7 time flash
		Timer indicator	3 time flash
		Economy indicator	Continuous flash
		Error code	E: 73
Detective actuator	Outdoor unit main PCB	When heat exchanger temperature thermistor open or short circuit is detected at power on or while running the compressor	
	Heat exchanger temperature thermistor		
Forecast of cause			Connector failure
			Thermistor failure
			Main PCB failure

### Check point 1. Check connection of connector

- Check if connector is loose or removed.
- Check erroneous connection.
- Check if thermistor cable is open

→ Reset power when reinstalling due to removed connector or incorrect wiring.



### Check point 2. Remove connector and check thermistor resistance value

- For the outdoor unit heat exchanger thermistor resistance value, refer to "[Thermistor resistance values](#)" on page 03-47.
- If thermistor is either open or shorted, replace it and reset the power.

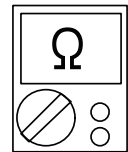

### Check point 3. Check voltage of main PCB

Make sure circuit diagram of outdoor unit and check terminal voltage at thermistor (DC 5.0 V).

**NOTE:** For details of thermistor connector, refer to "[Wiring diagrams](#)" in Chapter 2. TECHNICAL DATA AND PARTS LIST on page 02-21.

If the voltage does not appear, replace main PCB.



**End**

## 2-17. E: 74. Outdoor temperature thermistor error (Outdoor unit)

Indicator	Indoor unit	Operation indicator	7 time flash
		Timer indicator	4 time flash
		Economy indicator	Continuous flash
		Error code	E: 74
Detective actuator	Outdoor unit main PCB	When outdoor temperature thermistor open or short circuit is detected at power on or while running the compressor	
	Outdoor temperature thermistor		
Forecast of cause		Connector failure	
		Thermistor failure	
		Main PCB failure	

### Check point 1. Check connection of connector

- Check if connector is loose or removed.
- Check erroneous connection.
- Check if thermistor cable is open

-> Reset power when reinstalling due to removed connector or incorrect wiring.



### Check point 2. Remove connector and check thermistor resistance value

- For the outdoor temperature thermistor resistance value, refer to "[Thermistor resistance values](#)" on page 03-47.
- If thermistor is either open or shorted, replace it and reset the power.

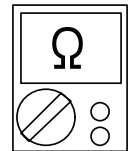

### Check point 3. Check voltage of main PCB

Make sure circuit diagram of outdoor unit and check terminal voltage at thermistor (DC 5.0 V).

**NOTE:** For details of thermistor connector, refer to "[Wiring diagrams](#)" in Chapter 2. TECHNICAL DATA AND PARTS LIST on page 02-21.

(09-14 models: P5)

If the voltage does not appear, replace main PCB.



**End**

## 2-18. E: 84. Current sensor error (Outdoor unit)

Indicator	Indoor unit	Operation indicator	8 time flash
		Timer indicator	4 time flash
		Economy indicator	Continuous flash
		Error code	E: 84
Detective actuator	Outdoor unit	main PCB	When input current sensor has detected 0 A, while inverter compressor is operating at higher than 56 rps, after 1 minute upon starting the compressor. (Except during the defrost operation)
Forecast of cause			Defective connection of electrical components
			External cause
			Main PCB failure

Check point 1. Reset power supply and operate

Does error indication show again?

If no, go to "Check point 1-2".



Check point 2. Check connections of outdoor unit electrical components

- Check if the terminal connection is loose.
- Check if connector is removed.
- Check erroneous connection.
- Check if cable is open.

Upon correcting the removed connector or miswiring, reset the power.



Check point 3. Replace the main PCB

If Check point 1, 2 do not improve the symptom, replace the main PCB.



**End**

Check point 1-2. Check external cause at Indoor and Outdoor (Voltage drop or Noise)

- Instant drop: Check if there is a large load electric apparatus in the same circuit.
- Momentary power failure: Check if there is a defective contact or leak current in the power supply circuit.
- Noise: Check if there is any equipment causing harmonic wave near electric line. (Neon bulb or electric equipment that may cause harmonic wave)  
Check the complete insulation of grounding.



**End**

## 2-19. E: 94. Trip detection (Outdoor unit)

Indicator	Indoor unit	Operation indicator	9 time flash
		Timer indicator	4 time flash
		Economy indicator	Continuous flash
		Error code	E: 94
Detective actuator	Outdoor unit	Main PCB	Protection stop by over-current generation after inverter compressor start processing completed generated consecutively 10 times. <b>NOTE:</b> The number of generations is reset when the compressor starts up.
		Compressor	
Forecast of cause		Outdoor unit fan operation defective, foreign matter on heat-exchanger, excessive rise of ambient temperature	
		Main PCB failure	
		Inverter compressor failure (lock, winding short)	

Check point 1. Check the outdoor unit fan operation, heat-exchanger, ambient temperature

- No obstructions in air passages?
- Heat exchange fins clogged
- Outdoor unit fan motor check
- Ambient temperature not raised by the effect of other heat sources?
- Discharged air not sucked in?



Check point 2. Replace the main PCB

If Check point 1 do not improve the symptom, replace the main PCB.



Check point 3. Replace compressor

If Check point 2 do not improve the symptom, change compressor.



**End**

## 2-20. E: 95. Compressor motor control error (Outdoor unit)

Indicator	Indoor unit	Operation indicator	9 time flash
		Timer indicator	5 time flash
		Economy indicator	Continuous flash
		Error code	E: 95
Detective actuator	Outdoor unit	Main PCB	<ol style="list-style-type: none"> <li>1. When running the compressor, if the detected rotor location is out of phase with actual rotor location more than 90°, the compressor stops.</li> <li>2. After the compressor restarts, if the same operation is repeated within 40 seconds, the compressor stops again.</li> <li>3. If 1. and 2. repeats 5 times, the compressor stops permanently.</li> </ol>
		Compressor	
Forecast of cause		Defective connection of electrical components	
		Main PCB failure	
		Compressor failure	

### Check point 1. Check Noise from Compressor

Turn on Power and check operation noise.  
→ If an abnormal noise show, replace compressor.



### Check point 2. Check connection of around the compressor components

For compressor terminal, main PCB

- Check if connector is removed.
- Check erroneous connection.
- Check if cable is open. (Refer to inverter compressor in "[Service parts information](#)" on page 03-40.)

→ Upon correcting the removed connector or mis-wiring, reset the power.



### Check point 3. Replace the main PCB

If Check point 1, 2 do not improve the symptom, replace the main PCB.



### Check point 4. Replace compressor

If Check point 3 do not improve the symptom, change compressor.



**End**

## 2-21. E: 97. Outdoor unit fan motor error (Outdoor unit)

Indicator	Indoor unit	Operation indicator	9 time flash
		Timer indicator	7 time flash
		Economy indicator	Continuous flash
		Error code	E: 97
Detective actuator	Outdoor unit	Main PCB	<ol style="list-style-type: none"> <li>When outdoor fan rotation speed is less than 100 rpm in 20 seconds after fan motor starts, fan motor stops.</li> <li>After fan motor restarts, if the same operation within 60 seconds is repeated 3 times in a row, compressor and fan motor stops.</li> <li>If 1. and 2. repeats 5 times in a row, compressor and fan motor stops permanently.</li> </ol>
		Fan motor	
Forecast of cause		Fan rotation failure	
		Motor protection by surrounding temperature rise	
		Main PCB failure	
		Outdoor unit fan motor	

### Check point 1. Check rotation of fan

Rotate the fan by hand when operation is off. (Check if fan is caught, dropped off or locked motor)  
→ If fan or bearing is abnormal, replace it.



### Check point 2. Check ambient temperature around motor

Check excessively high temperature around the motor. (If there is any surrounding equipment that causes heat)  
→ Upon the temperature coming down, restart operation.



### Check point 3. Check outdoor unit fan motor

Check outdoor unit fan motor. (Refer to outdoor unit fan motor in "[Service parts information](#)" on page 03-40.)  
→ If outdoor unit fan motor is abnormal, replace outdoor unit fan motor and main PCB.



### Check point 4. Check output voltage of main PCB

Check outdoor unit circuit diagram and the voltage. (Measure at main PCB side connector)

**NOTE:** For details of wiring diagram, refer to "[Wiring diagrams](#)" in Chapter 2. TECHNICAL DATA AND PARTS LIST on page 02-21.



Read wire	DC voltage
Red—Black	306—374 V
White—Black	15 ±1.5 V

→ If the voltage is not correct, replace Main PCB.



**End**



## 2-22. E: 99. 4-way valve error (Outdoor unit)

Indicator	Indoor unit	Operation indicator	9 time flash
		Timer indicator	9 time flash
		Economy indicator	Continuous flash
		Error code	E: 99
Detective actuator	Indoor unit	main PCB	When the indoor heat exchanger temperature is compared with the room temperature, and either following condition is detected continuously two times, the compressor stops. Indoor heat exchanger temp. - Room temp. > 10°C (Cooling or Dry operation) Indoor heat exchanger temp. - Room temp. < -10°C (Heating operation) If the same operation is repeated 5 times, the compressor stops permanently.
	Heat exchanger temperature thermistor		
	Room temperature thermistor		
	4-way valve		
Forecast of cause			Connector connection failure
			Thermistor failure
			Coil failure
			4-way valve failure
			Main PCB failure

### Check point 1. Check connection of connector

- Check if connector is removed.
- Check erroneous connection.
- Check if thermistor cable is open.

→ Upon correcting the removed connector or mis-wiring, reset the power.



### Check point 2. Check each thermistor

- Isn't it fallen off the holder?
- Is there a cable pinched?

Check characteristics of room thermistor and indoor unit heat exchanger thermistor.

For the thermistor resistance value, refer to "[Thermistor resistance values](#)" on page 03-47.

→ If defective, replace the thermistor.



**Check point 3. Check the solenoid coil and 4-way valve**

**NOTE:** Refer solenoid coil and 4-way valve in "[Service parts information](#)" on page 03-40.

- **Solenoid coil**  
Remove P60 from PCB and check the resistance value of coil. Resistance value is 1.88 kΩ — 2.29 kΩ (at 20°C).  
→ If it is open or abnormal resistance value, replace solenoid coil.
- **4-way valve**  
Check each piping temperature, and the location of the valve by the temperature difference.  
If the value location is not proper, replace 4-way valve.

**Check point 4. Replace main PCB**

If Check Point 1 to 3 do not improve the symptom, replace main PCB.



**End**

## 2-23. E: A1. Discharge temperature error (Outdoor unit)

Indicator	Indoor unit	Operation indicator	10 time flash
		Timer indicator	1 time flash
		Economy indicator	Continuous flash
		Error code	E: A1
Detective actuator	Outdoor unit main PCB	Protection stop by discharge temperature $\geq 110^{\circ}\text{C}$ during compressor operation generated 2 times within 24 hours.	
	Discharge temperature thermistor		
Forecast of cause	3-way valve not opened		
	EEV or capillary tube defective, strainer clogged		
	Outdoor unit operation failure, foreign matter on heat exchanger		
	Discharge temperature thermistor failure		
	Insufficient refrigerant		
	Main PCB failure		

Check point 1. Check if 3-way valve is open

If the 3-way valve is closed, open the 3-way valve and check operation.

**NOTE:** For cooling operation, check gas side of the 3-way valve.  
For heating operation, check liquid side of the 3-way valve.



Check point 2. Check any of the electronic expansion valve (EEV), capillary tube, or strainer, or all

- Check if EEV open or there is a capillary tube defect.  
Refer to outdoor unit Electronic Expansion Valve (EEV) or Capillary tube in "[Service parts information](#)" on page 03-40.
- Check the strainer clogging.



Check point 3. Check the outdoor unit fan and heat exchanger

- Check for foreign object at heat exchanger
- Check if fan can be rotated by hand.
- Check the motor. (Refer to outdoor unit fan motor in "[Service parts information](#)" on page 03-40.)



Check point 4. Check the discharge thermistor

The discharge temperature thermistor characteristics check. (Check by disconnecting thermistor from PCB.)

**NOTE:** For the characteristics of the thermistor, refer to "[Thermistor resistance values](#)" on page 03-47.



Check point 5. Check the refrigerant amount

Check the refrigerant leakage.



Check point 6. Replace the main PCB

If check point 1 to 5 do not improve the symptom, replace the main PCB.



**End**

## 2-24. E: A3. Compressor temperature error (Outdoor unit) (For 14 model)

Indicator	Indoor unit	Operation indicator	10 time flash
		Timer indicator	3 time flash
		Economy indicator	Continuous flash
		Error code	E: A3
Detective actuator	Outdoor unit main PCB	Protection stop by compressor temperature $\geq 108^{\circ}\text{C}$ during compressor operation generated 2 times within 24 hours.	
	Compressor temperature thermistor		
Forecast of cause	3-way valve not opened		
	EEV defective, strainer clogged		
	Outdoor unit operation failure, foreign matter on heat exchanger		
	Compressor temperature thermistor failure		
	Insufficient refrigerant		
	Main PCB failure		

Check point 1. Check if 3-way valve is open

If the 3-way valve is closed, open the 3-way valve and check operation.

**NOTE:** For cooling operation, check gas side of the 3-way valve.  
For heating operation, check liquid side of the 3-way valve.



Check point 2. Check the electronic expansion valve (EEV) and strainer

- Check if EEV open.  
Refer to outdoor unit Electronic Expansion Valve (EEV) in "[Service parts information](#)" on page 03-40.
- Check the strainer clogging.



Check point 3. Check the outdoor unit fan and heat exchanger

- Check for foreign object at heat exchanger
- Check if fan can be rotated by hand.
- Check the motor. (Refer to outdoor unit fan motor in "[Service parts information](#)" on page 03-40.)



Check point 4. Check the compressor thermistor

The compressor temperature thermistor characteristics check. (Check by disconnecting thermistor from PCB.)

**NOTE:** For the characteristics of the thermistor, refer to "[Thermistor resistance values](#)" on page 03-47.



Check point 5. Check the refrigerant amount

Check the refrigerant leakage.



Check point 6. Replace the main PCB

If check point 1 to 5 do not improve the symptom, replace the main PCB.



**End**

## 3. Troubleshooting without error code

### 3-1. Indoor unit—No power

Forecast of cause	Power supply failure
	External cause
	Electrical components defective

#### Check point 1. Check installation condition

- Isn't the breaker down?
- Check loose or removed connection cable.

-> If abnormal condition is found, correct it by referring to the installation manual or the "DESIGN & TECHNICAL MANUAL".



#### Check point 2. Check external cause at indoor and outdoor (voltage drop or noise)

- Instant drop: Check if there is a large load electric apparatus in the same circuit.
- Momentary power failure: Check if there is a defective contact or leak current in the power supply circuit.
- Noise: Check if there is any equipment causing harmonic wave near electric line. (Neon bulb or electric equipment that may cause harmonic wave)  
Check the complete insulation of grounding.



#### Check point 3. Check electrical components

Check the voltage of power supply.

Check if AC 207 to 253 V appears at outdoor unit terminal L—N.

-> If no, go to "[Check point 1](#)" and "[Check point 2](#)".



- Check fuse in filter PCB.  
If fuse is open, check if the wiring between terminal and filter PCB is loose, and replace fuse.
- Check varistor in filter PCB.  
If varistor is defective, there is a possibility of an abnormal power supply.  
Check the correct power supply and replace varistor.  
Upon checking the normal power supply, replace varistor.



**End**

## 3-2. Outdoor unit—No power

Forecast of cause	Power supply failure
	External cause
	Electrical components defective

### Check point 1. Check installation condition

- Is the circuit breaker on or off?
- Check loose or removed connection cable.

→ If abnormal condition is found, correct it by referring to the installation manual or the "DESIGN & TECHNICAL MANUAL".



### Check point 2. Check external cause at indoor and outdoor (voltage drop or noise)

- Instant drop: Check if there is a large load electric apparatus in the same circuit.
- Momentary power failure: Check if there is a defective contact or leak current in the power supply circuit.
- Noise: Check if there is any equipment causing harmonic wave near electric line. (Neon bulb or electric equipment that may cause harmonic wave)  
Check the complete insulation of grounding.



### Check point 3. Check electrical components

Check the voltage of power supply.

Check if AC 207 to 253 V appears at outdoor unit terminal L—N

→ If no, go to "[Check point 1](#)" and "[Check point 2](#)".

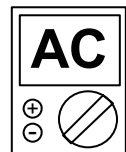

- Check fuse in main PCB.  
If fuse is open, check if the wiring between terminal and main PCB is loose, and replace fuse.



### Check point 4. Replace the main PCB

If check point 1 to 3 do not improve the symptom, replace the main PCB.



**End**



### 3-3. No operation (Power is on)

Forecast of cause	Setting/ Connection failure
	External cause
	Electrical components defective

#### Check point 1. Check indoor and outdoor installation condition

- Indoor unit:
    - Check incorrect wiring between indoor unit and remote controller.
    - Check if there is an open cable connection.
  - Are these indoor unit, outdoor unit, and remote controller suitable model names to connect?
- > If there is some abnormal condition, correct it by referring to the installation manual and "DESIGN & TECHNICAL MANUAL".



Turn off the power and check correct followings.

- Is there loose or removed communication line of indoor unit and outdoor unit?



#### Check point 2. Check external cause at indoor and outdoor (Voltage drop or Noise)

- Instant drop: Check if there is a large load electric apparatus in the same circuit.
- Momentary power failure: Check if there is a defective contact or leak current in the power supply circuit.
- Noise: Check if there is any equipment causing harmonic wave near electric line. (Neon bulb or electric equipment that may cause harmonic wave)  
Check the complete insulation of grounding.



#### Check point 3. Check wired remote controller and controller PCB

Check voltage at CNC01 (terminal 1—3) of main PCB.  
(Power supply to remote controller)

- If it is DC 13 V, remote controller is failure. (The controller PCB is normal)  
-> Replace remote controller.
- If it is DC 0 V, controller PCB is failure. (Check the remote controller once again)  
-> Replace controller PCB.



#### Check point 4. Replace main PCB

If check point 1 to 3 do not improve the symptom, change main PCB.



**End**

## 3-4. No cooling/No heating

Forecast of cause	Indoor unit error
	Outdoor unit error
	Effect by surrounding environment
	Connection pipe/Connection wire failure
	Refrigeration cycle failure

### Check point 1. Check Indoor unit

- Does Indoor unit fan run in the HIGH mode?
- Is air filter dirty?
- Is heat exchanger clogged?
- Check if energy save function is operated.



### Check point 2. Check outdoor unit operation

- Check if outdoor unit is operating.
- Check any objects that obstruct the air flow route.
- Check if heat exchanger is clogged.
- Is the valve open?



### Check point 3. Check site condition

- Is capacity of Indoor unit fitted to the room size?
- Any windows open or direct sunlight?



### Check point 4. Check indoor/outdoor installation condition

- Check connection pipe (specified pipe length and pipe diameter?)
- Check any loose or removed communication line.

→ If there is an abnormal condition, correct it by referring to the installation manual or the "DESIGN & TECHNICAL MANUAL".



### Check point 5. Check Refrigeration cycle

- Check if strainer is clogged (Refer to the figure below).
- Measure gas pressure, and if there is a leakage, correct it.
- Check if EEV open or there is a capillary tube defect.  
Refer to outdoor unit Electronic Expansion Valve (EEV) or Capillary tube in "[Service parts information](#)" on page 03-40.
- Check compressor.  
Refer to compressor in "[Service parts information](#)" on page 03-40.  
Refer to inverter compressor in "[Service parts information](#)" on page 03-40.

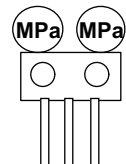

**NOTE:** When recharging the refrigerant, make sure to perform vacuuming, and recharge the specified amount.



**End**

**NOTES:**

- Strainer normally does not have temperature difference between inlet and outlet as shown below.

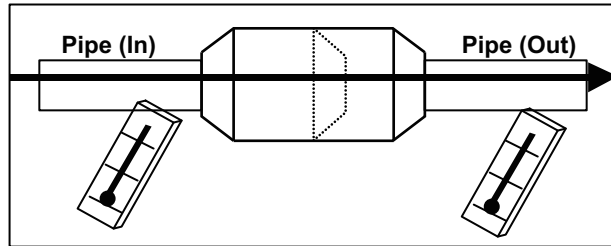

- If there is a difference like shown below, there is a possibility of inside clogged. In this case, replace the strainer.

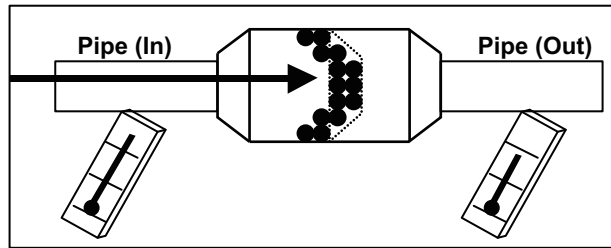

## 3-5. Abnormal noise

Forecast of cause	Abnormal installation (indoor unit/outdoor unit)
	Fan failure (indoor unit/outdoor unit)
	Compressor failure (outdoor)

### Diagnosis method when abnormal noise is occurred

Abnormal noise is coming from Indoor unit.  
(Check and correct followings)



- Is main unit installed in stable condition?
- Is the installation of air suction grille and front panel normal?



- Is fan broken or deformed?
- Is the screw of fan loose?
- Is there any object which obstruct the fan rotation?



**End**

Abnormal noise is coming from Outdoor unit.  
(Check and correct followings)



- Is main unit installed in stable condition?
- Is fan guard installed normally?



- Is fan broken or deformed?
- Is the screw of fan loose?
- Is there any object which obstruct the fan rotation?



Check if vibration noise by loose bolt or contact noise of piping is happening.



Is compressor locked?

- Check Compressor  
Refer to compressor and inverter compressor in "[Service parts information](#)" on page 03-40.



**End**

## 3-6. Water leaking

Forecast of cause

Erroneous installation

Drain hose failure

Diagnosis method when water leak occurs

- Is main unit installed in stable condition?
- Is main unit broken or deformed at the time of transportation or maintenance?



- Is drain hose connection loose?
- Is there a trap in drain hose?
- Is drain hose clogged?



Is fan rotating?



**End**

Diagnosis method when water is spitting out

Is the filter clogged?



Check gas pressure and correct it if there was a gas leak.

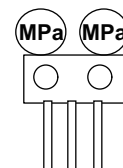

**End**

## 4. Service parts information

### 4-1. Compressor

Diagnosis method of compressor (If outdoor unit LED displays error, refer to troubleshooting)

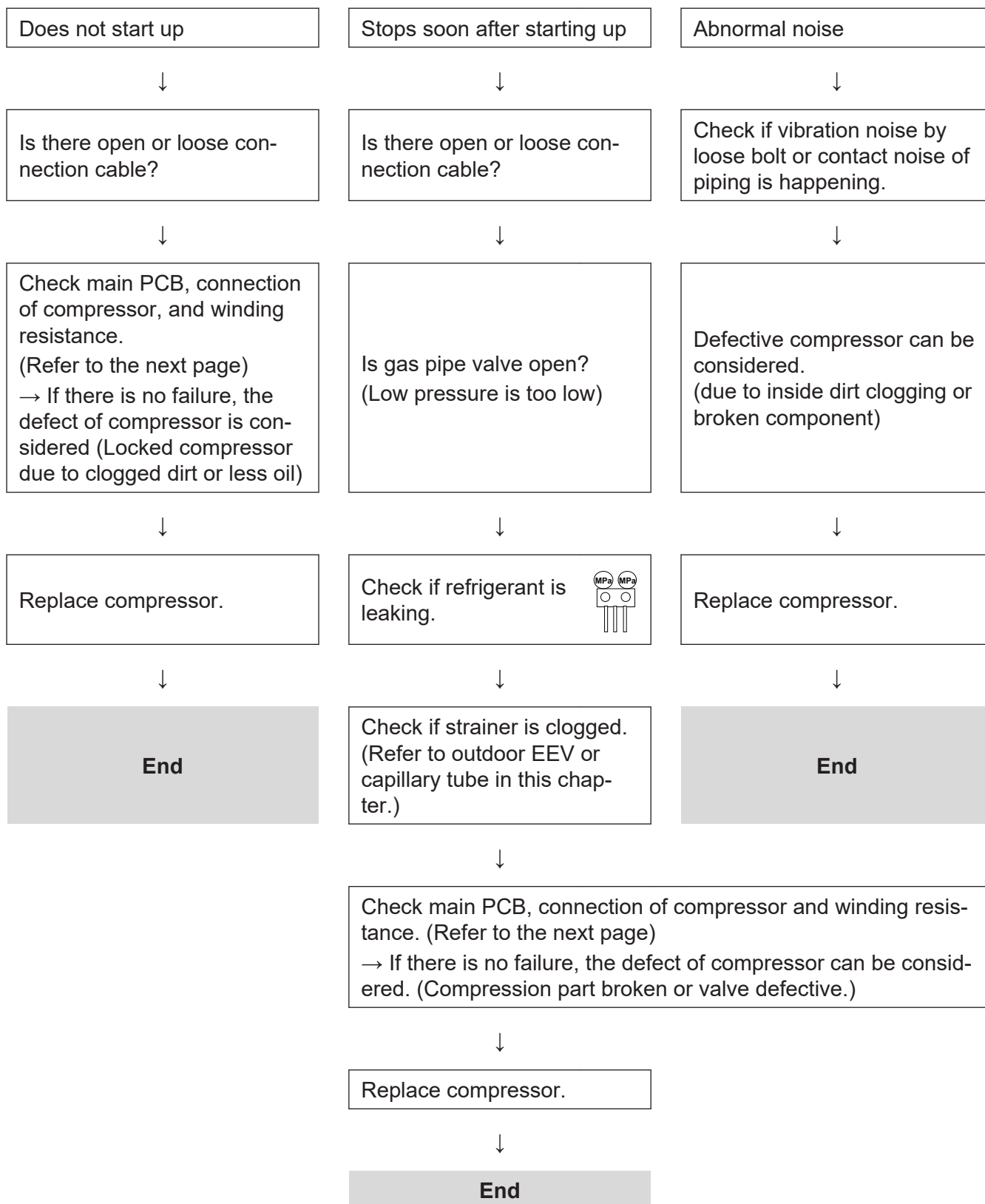

## 4-2. Inverter compressor

### Check point 1. Check connection

- Check terminal connection of compressor (loose or incorrect wiring)

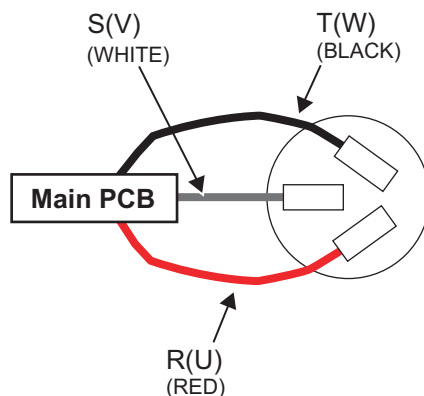

- Check terminal connection of main PCB (loose or incorrect wiring)

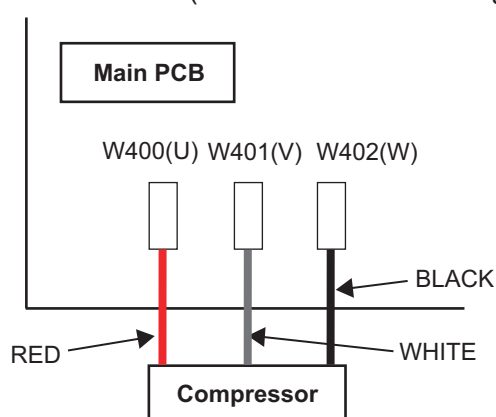

↓

### Check point 2. Check winding resistance

Check winding resistance of each terminal.

Resistance value

- 09/12 model: 1.910  $\Omega$  at 20°C
- 14 model: 1.916  $\Omega$  at 20°C

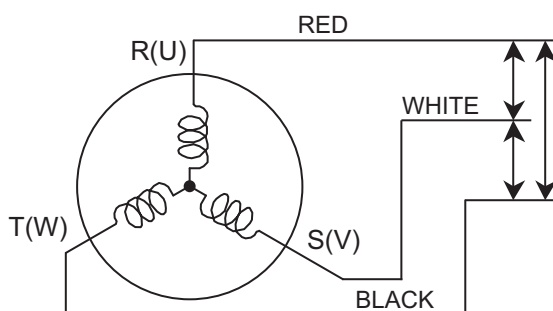
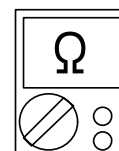

→ If the resistance value is 0  $\Omega$  or infinite, replace compressor.

↓

### Check point 3. Replace inverter PCB

If check point 1 to 2 do not improve the symptom, replace main PCB.

## 4-3. Outdoor unit Electronic Expansion Valve (EEV)

### Check point 1. Check connections

Check connection of connector. (Loose connector or open cable)

**NOTE:** For details of wiring diagram, refer to "Wiring diagrams" in Chapter 2. TECHNICAL DATA AND PARTS LIST on page 02-21.

### Check point 2. Check coil of EEV

Remove connector, check each winding resistance of coil.

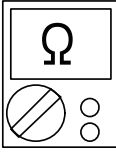
Read wire	Resistance value
White - Red	$46 \Omega \pm 4 \Omega$ at 20°C 
Yellow - Red	
Orange - Red	
Blue - Red	

→ If Resistance value is abnormal, replace EEV.

### Check point 3. Check voltage from main PCB

Remove connector and check voltage (DC 12 V)

→ If it does not appear, replace main PCB.



### Check point 4. Check noise at start up

Turn on the power and check the operation noise.

→ If an abnormal noise does not show, replace main PCB.

### Check point 5. Check opening and closing operation of valve

When valve is closed, it has a temp. difference between inlet and outlet

**CLOSE**  
 Example : Hot Gas

Pipe (In)  
 Hi TEMP.

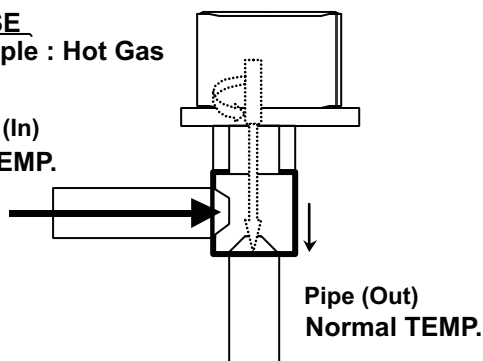

If it is open, it has no temp. difference between inlet and outlet

**OPEN**  
 Example : Hot Gas

Pipe (In)  
 Hi TEMP.

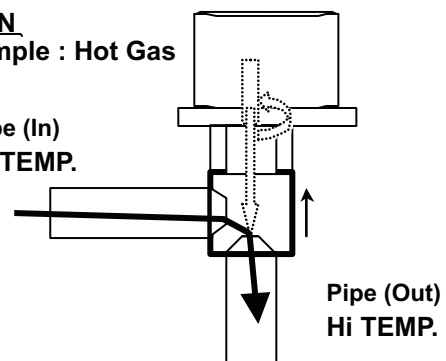



## Check point 6. Check strainer

- Strainer normally does not have temperature difference between inlet and outlet as shown below.

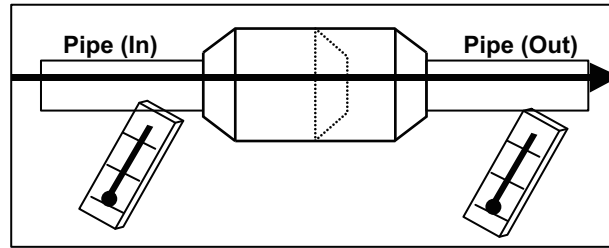

- If there is a difference like shown below, there is a possibility of inside clogged. In this case, replace the strainer.

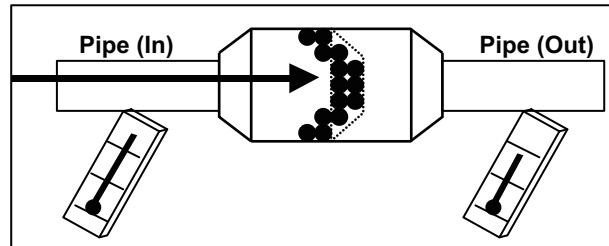

## 4-4. Indoor unit fan motor

### Check point 1. Check rotation of fan

Rotate the fan by hand when operation is off.  
 (Check if fan is caught, dropped off or locked motor)  
 → If fan or bearing is abnormal, replace it.

### Check point 2. Check resistance of indoor fan motor

Refer to below. Circuit-test “Vm” and “GND” terminal

**NOTE:** Vm: DC voltage, GND: Earth terminal

→ If they are short-circuited (below 300 kΩ), replace indoor fan motor and controller PCB.

Pin number (wire color)	Terminal function (symbol)
1 (Red)	DC voltage (Vm)
2	No function
3	No function
4 (Black)	Ground terminal (GND)
5 (White)	Control voltage (Vcc)
6 (Yellow)	Speed command (Vsp)
7 (Blue)	Feed back (FG)

## 4-5. Outdoor unit fan motor

### Check point 1. Check rotation of fan

Rotate the fan by hand when operation is off.  
 (Check if fan is caught, dropped off or locked motor)  
 → If fan or bearing is abnormal, replace it.

### Check point 2. Check resistance of outdoor fan motor

Refer to below. Circuit-test "Vm" and "GND" terminal

**NOTE:** Vm: DC voltage, GND: Earth terminal

→ If they are short-circuited (below 300 kΩ), replace outdoor fan motor and controller PCB.

Pin number (wire color)	Terminal function (symbol)
1 (Red)	DC voltage (Vm)
2	No function
3	No function
4 (Black)	Ground terminal (GND)
5 (White)	Control voltage (Vcc)
6 (Yellow)	Speed command (Vsp)
7 (Blue)	Feed back (FG)

## 4-6. 4-way valve coil (solenoid coil)/4-way valve

### Check point 1. Check connection

- Check the connection of connector P60.

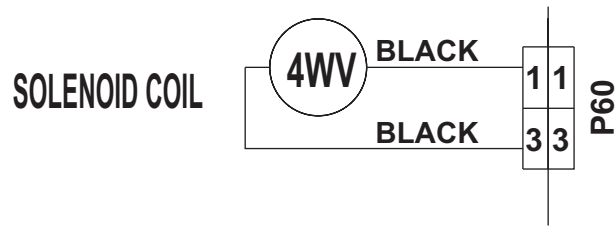

### Check Point 2 : Check solenoid coil

Remove P60 from PCB and check the resistance value of coil.

Resistance Value  $\approx 1.97 \text{ k}\Omega$

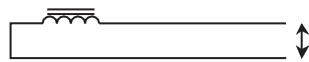

→ If it is Open or abnormal resistance value, replace solenoid coil.

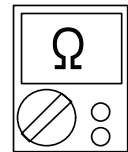

### Check Point 3: Check operation of 4-way valve

Check each piping temperature, and confirm the location of the valve by the temperature difference

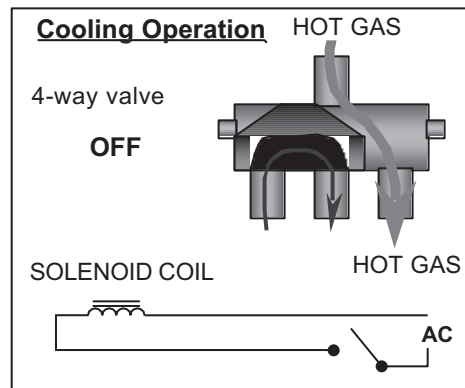
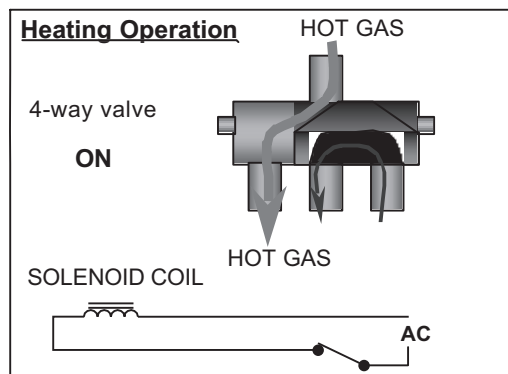

→ If the valve location is not proper, replace 4-way valve.



### Check Point 4: Replace main PCB

If none of Checks 1 to 3 apply, replace the main PCB.

## 5. Thermistor resistance values

### 5-1. Indoor unit

#### ■ Room temperature thermistor

Temperature (°C)	Resistance (kΩ)	Voltage (V)
-10.0	58.25	0.73
-5.0	44.03	0.93
0.0	33.62	1.15
5.0	25.93	1.39
10.0	20.18	1.66
15.0	15.84	1.94
20.0	12.54	2.22
25.0	10.00	2.50
30.0	8.04	2.77
35.0	6.51	3.03
40.0	5.30	3.27
45.0	4.35	3.49

#### ■ Heat exchanger temperature thermistor

Temperature (°C)	Resistance (kΩ)	Voltage (V)
-30.0	1,131.91	0.21
-25.0	804.52	0.29
-20.0	579.59	0.40
-15.0	422.89	0.53
-10.0	312.27	0.69
-5.0	233.21	0.88
0.0	176.03	1.10
5.0	134.23	1.36
10.0	103.34	1.63
15.0	80.28	1.92
20.0	62.91	2.21
25.0	49.70	2.51
30.0	39.57	2.79
35.0	31.74	3.06
40.0	25.64	3.30
45.0	20.85	3.53
50.0	17.06	3.73
55.0	14.05	3.90
60.0	11.64	4.02
65.0	9.69	4.19

## 5-2. Outdoor unit

### ■ Discharge temperature thermistor

Temperature (°C)	Resistance (kΩ)	Voltage (V)
-30.0	984.49	0.03
-25.0	709.67	0.05
-20.0	518.22	0.06
-15.0	383.06	0.09
-10.0	286.42	0.11
-5.0	216.49	0.15
0.0	165.33	0.19
5.0	127.48	0.25
10.0	99.21	0.31
15.0	77.88	0.39
20.0	61.64	0.49
25.0	49.17	0.60
30.0	39.52	0.72
35.0	31.99	0.86
40.0	26.07	1.02
45.0	21.38	1.19
50.0	17.64	1.37
55.0	14.65	1.56
60.0	12.23	1.76
65.0	10.26	1.97
70.0	8.65	2.17
75.0	7.34	2.38
80.0	6.25	2.58
85.0	5.34	2.77
90.0	4.59	2.96
95.0	3.96	3.13
100.0	3.43	3.30
105.0	2.98	3.45
110.0	2.60	3.59
115.0	2.28	3.72
120.0	2.00	3.84

## ■ Heat exchanger temperature thermistor

Temperature (°C)	Resistance (kΩ)	Voltage (V)
-30.0	95.57	0.24
-25.0	68.89	0.32
-20.0	50.31	0.43
-15.0	37.19	0.57
-10.0	27.81	0.73
-5.0	21.02	0.92
0.0	16.05	1.14
5.0	12.38	1.39
10.0	9.63	1.65
15.0	7.56	1.93
20.0	5.98	2.21
25.0	4.77	2.49
30.0	3.84	2.77
35.0	3.11	3.02
40.0	2.53	3.26
45.0	2.08	3.48
50.0	1.71	3.67
55.0	1.42	3.85
60.0	1.19	4.00
65.0	1.00	4.13
70.0	0.84	4.25
75.0	0.71	4.35
80.0	0.61	4.43

## ■ Outdoor temperature thermistor

Temperature (°C)	Resistance (kΩ)	Voltage (V)
-30.0	224.33	0.73
-25.0	159.71	0.97
-20.0	115.24	1.25
-15.0	84.21	1.56
-10.0	62.28	1.90
-5.0	46.58	2.26
0.0	35.21	2.61
5.0	26.88	2.94
10.0	20.72	3.25
15.0	16.12	3.52
20.0	12.64	3.76
25.0	10.00	3.97
30.0	7.97	4.14
35.0	6.40	4.28
40.0	5.18	4.41
45.0	4.21	4.51
50.0	3.45	4.59
55.0	2.85	4.65





## 4. CONTROL AND FUNCTIONS

# CONTENTS

## 4. CONTROL AND FUNCTIONS

<b>1. Rotation number control of compressor.....</b>	<b>04-1</b>
1-1. Cooling operation .....	04-1
1-2. Heating operation .....	04-3
1-3. Dry operation .....	04-4
1-4. Rotation number of compressor at normal start-up .....	04-5
1-5. Limitation of compressor rotation number by outdoor temperature.....	04-6
<b>2. Auto changeover operation.....</b>	<b>04-8</b>
<b>3. Fan control.....</b>	<b>04-10</b>
3-1. Indoor fan control.....	04-10
3-2. Outdoor fan control .....	04-13
<b>4. Louver control .....</b>	<b>04-16</b>
4-1. Horizontal louver control .....	04-16
4-2. Adjust the horizontal louver .....	04-16
4-3. Swing operation.....	04-17
<b>5. Timer operation control .....</b>	<b>04-18</b>
5-1. Wireless remote control .....	04-18
5-2. Wired remote control .....	04-20
<b>6. Defrost operation control .....</b>	<b>04-23</b>
6-1. Defrost operation in heating operation stopped .....	04-24
<b>7. Various control .....</b>	<b>04-25</b>
7-1. Auto restart.....	04-25
7-2. MANUAL AUTO operation.....	04-25
7-3. Forced cooling operation .....	04-26
7-4. 10 °C HEAT operation .....	04-26
7-5. ECONOMY operation .....	04-26
7-6. POWERFUL operation .....	04-27
7-7. Fresh air control.....	04-27
7-8. Compressor preheating .....	04-27
7-9. Electronic expansion valve control .....	04-28
7-10. Prevention to restart for 3 minutes (3 minutes st) .....	04-28
7-11. 4-way valve control.....	04-28
7-12. Outdoor unit low noise operation .....	04-28
<b>8. Various protections.....</b>	<b>04-29</b>
8-1. Discharge gas temperature over-rise prevention control .....	04-29
8-2. Anti-freezing control (cooling and dry mode) .....	04-29
8-3. Current release control .....	04-30
8-4. Cooling pressure over-rise protection.....	04-31
8-5. Compressor temperature protection .....	04-31
8-6. High pressure protection .....	04-31
8-7. Low outdoor temperature protection.....	04-31

## **CONTENTS (continued)**

8-8. High temperature and high pressure release control .....	04-32
---	-------



# 1. Rotation number control of compressor

## 1-1. Cooling operation

A sensor (room temperature thermistor) built in the indoor unit body will usually perceive difference or variation between a set temperature and present room temperature, and controls the operation rotation number of the compressor.

- If the room temperature is 6.0°C higher than a set temperature, the operation rotation number of compressor will attain to maximum performance.
- If the room temperature is 1.0°C lower than a set temperature, the compressor will be stopped.
- When the room temperature is within the range of +6.0°C to -1.0°C of the setting temperature, the rotation number of compressor is controlled within the range shown in the table below. However, the maximum rotation number is limited in the range shown in the figure below based on the indoor fan mode and the outdoor temperature.

- **Rotation number range of compressor**

Unit: rps

Model name	Minimum rotation number	Maximum rotation number
ASYG09KMCDN ASYG12KMCDN	8	63
ASYG14KMCDN	10	58

• Limit of maximum speed based on outdoor temperature

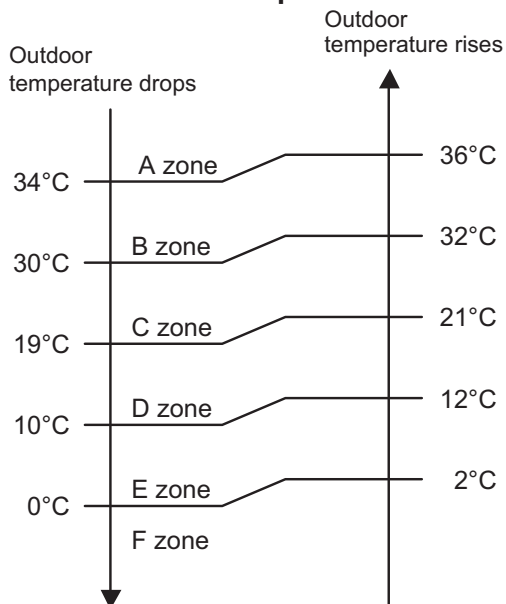

Unit: rps

Model name	Outdoor temperature zone	Indoor unit fan mode			
		HIGH	MED	LOW	QUIET
ASYG09KMCDN	A zone	63	34	24	18
	B zone	63	34	24	18
	C zone	63	34	24	18
	D zone	46	34	24	20
	E zone	46	32	24	16
	F zone	42	32	24	16
ASYG12KMCDN	A zone	63	32	24	16
	B zone	63	32	24	16
	C zone	63	32	24	16
	D zone	42	30	20	12
	E zone	42	30	20	12
	F zone	42	30	20	12
ASYG14KMCDN	A zone	58	30	22	14
	B zone	58	30	22	14
	C zone	58	30	22	14
	D zone	42	28	26	24
	E zone	42	28	26	24
	F zone	42	28	26	24

CONTROL AND FUNCTIONS

CONTROL AND FUNCTIONS

## 1-2. Heating operation

A sensor (room temperature thermistor) built in indoor unit body will usually perceive difference or variation between setting temperature and present room temperature, and controls operation rotation number of compressor.

- If the room temperature is 6.0°C lower than a set temperature, the operation rotation number of compressor will attain to maximum performance.
- If the room temperature is 1.0°C higher than a set temperature, the compressor will be stopped.
- When the room temperature is within the range of +1.0°C to -6.0°C of the setting temperature, the rotation number of compressor is controlled within the range shown below.

- **Rotation number range of compressor**

Unit: rps

Model name	Minimum rotation number	Maximum rotation number
ASYG09KMCDN ASYG12KMCDN	8	120
ASYG14KMCDN	10	130

- **Limit of maximum speed based on outdoor temperature**

In heating operation, maximum rotation number is defined by outdoor temperature and fan mode.

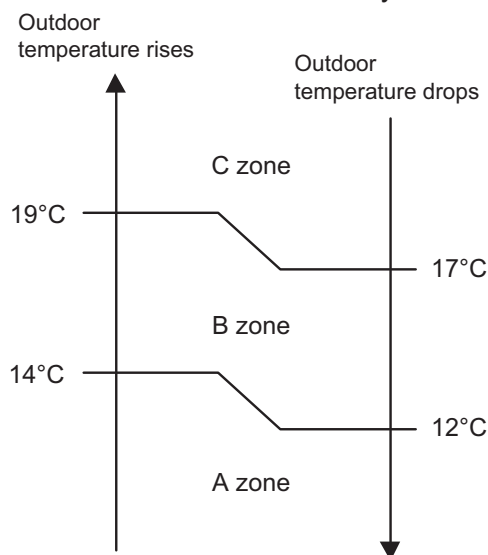

Unit: rps

Model name	Outdoor temperature zone	Indoor unit fan mode			
		HIGH	MED	LOW	QUIET
ASYG09KMCDN	A zone	120	94	68	54
	B zone	120	80	54	50
	C zone	120	74	54	46
ASYG12KMCDN	A zone	120	94	74	54
	B zone	120	87	54	39
	C zone	120	80	54	36
ASYG14KMCDN	A zone	130	87	63	39
	B zone	130	87	63	39
	C zone	130	87	63	39

## 1-3. Dry operation

The rotation number of compressor shall change according to the temperature, set temperature, and room temperature variation which the room temperature sensor of the indoor unit has detected as shown in the table below.

Zone is defined by set temperature and room temperature.

- **Rotation number range of compressor**

Unit: rps

Model name	Outdoor temperature zone	Operating frequency
ASYG09KMCDN	X zone	18
	J zone	14
	Y zone	0
ASYG12KMCDN	X zone	16
	J zone	12
	Y zone	0
ASYG14KMCDN	X zone	14
	J zone	12
	Y zone	0

- **Compressor control based on room temperature**

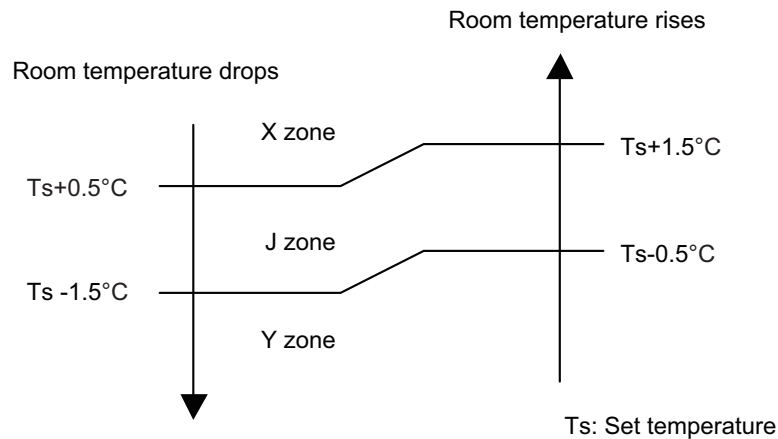



# 1-4. Rotation number of compressor at normal start-up

## ■ Models: AOYG09KMCDN and AOYG12KMCDN

Rotation number of compressor soon after starting is controlled as below.

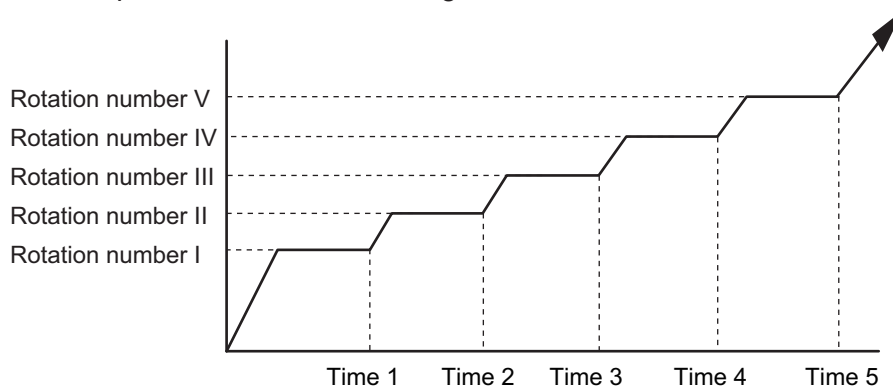

Rotation number (rps)	I 40	II 56	III 77	IV 90	V 99
Time (sec)	1 60	2 240	3 280	4 360	5 400

## ■ Model: AOYG14KMCDN

Rotation number of compressor soon after starting is controlled as below.

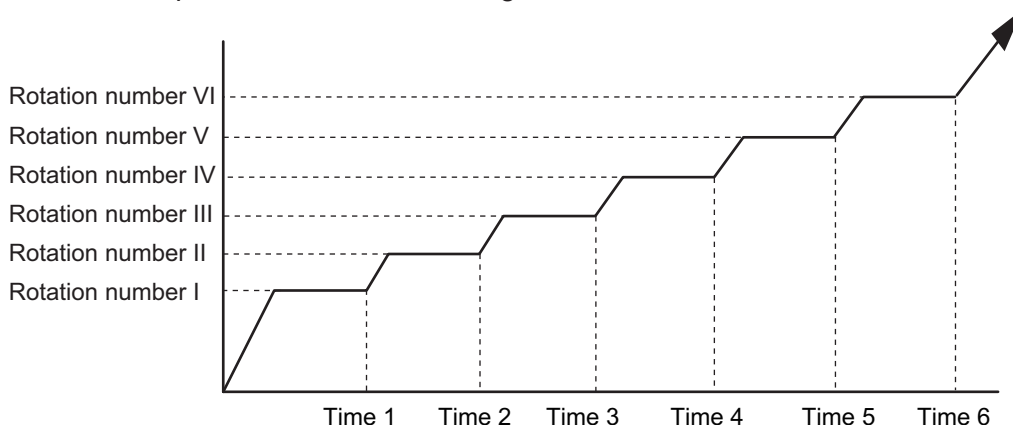

Rotation number (rps)	I 35	II 52	III 64	IV 71	V 89	VI 97
Time (sec)	1 60	2 140	3 170	4 200	5 350	6 410

CONTROL AND FUNCTIONS

CONTROL AND FUNCTIONS

## 1-5. Limitation of compressor rotation number by outdoor temperature

The minimum rotation number of compressor is limited by outdoor temperature as below.

- **Cooling/Dry mode**

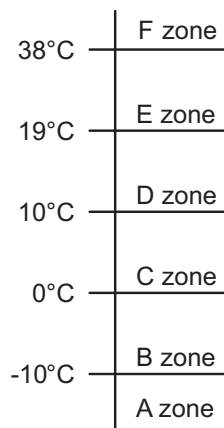

Unit: rps

Model name	Outdoor temperature zone	Limitation of compressor rotation number
AOYG09KMCDN	A zone	38
	B zone	38
	C zone	36
	D zone	31
	E zone	1
	F zone	30
AOYG12KMCDN	A zone	34
	B zone	34
	C zone	34
	D zone	34
	E zone	12
	F zone	18
AOYG14KMCDN	A zone	32
	B zone	32
	C zone	32
	D zone	32
	E zone	14
	F zone	22

- Heating mode

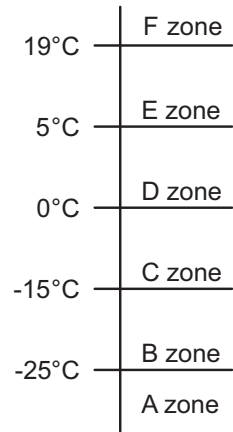

Unit: rps

Model name	Outdoor temperature zone	Limitation of compressor rotation number
AOYG09KMCDN	A zone	45
	B zone	25
	C zone	17
	D zone	10
	E zone	1
	F zone	1
AOYG12KMCDN	A zone	43
	B zone	25
	C zone	17
	D zone	10
	E zone	1
	F zone	1
AOYG14KMCDN	A zone	36
	B zone	31
	C zone	20
	D zone	14
	E zone	1
	F zone	1

## 2. Auto changeover operation

When the air conditioner is set to AUTO mode by remote controller, operation starts in the optimum mode from among heating, cooling, dry and monitoring modes. During operation, the optimum mode is automatically switched in accordance with temperature changes. The temperature can be set between 18°C and 30°C in 1.0°C steps.

- When operation starts, indoor fan and outdoor fan are operated for around 1 minute. Room temperature and outdoor temperature are sensed, and the operation mode is selected in accordance with the table below.

Room temperature	Operation mode
$Tr > Ts + 2^{\circ}\text{C}$	Cooling
$Ts + 2^{\circ}\text{C} \geq Tr \geq Ts - 2^{\circ}\text{C}$	Middle zone
$Tr < Ts - 2^{\circ}\text{C}$	Heating

Tr: Room temperature

Ts: Setting temperature

**NOTE:** When the operation mode is middle zone, indoor unit operation mode is selected as below.

- Same operation mode is selected as outdoor unit.  
If outdoor unit is operating in cooling and heating mode, indoor unit will be operated by the same operation mode.
- Selected by outdoor temperature.  
If outdoor unit is operating in other than cooling and heating mode, indoor unit will be operated according to the outdoor temperature as below.

Outdoor temp.	Operation mode
25°C or more	Cooling
Less than 25°C	Heating

- When the compressor was stopped for 6 consecutive minutes by temperature control function after the cooling or heating mode was selected as above, operation is switched to monitoring mode and the operation mode selection is done again.
- When the middle zone is selected on the predetermining of the operation mode, the operation mode before the changing to the monitoring mode is selected.

Operation flow chart

Ts: Setting temperature

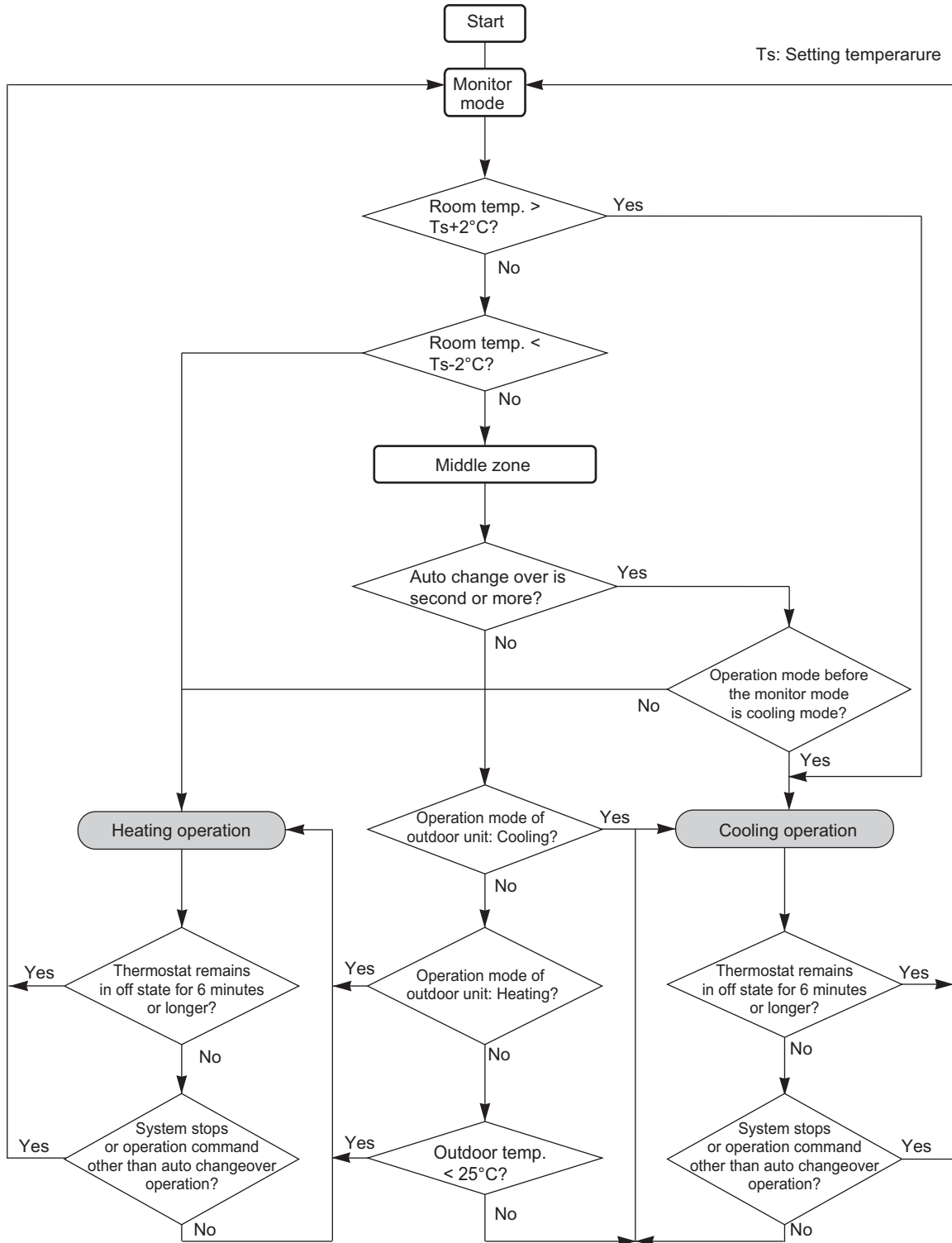

CONTROL AND FUNCTIONS

CONTROL AND FUNCTIONS

### 3. Fan control

Tr: Room temperature

Ts: Setting temperature

#### 3-1. Indoor fan control

##### ■ Fan speed

Indoor fan speed is defined as below.

Operation mode	Fan mode	Speed (rpm)		
		ASYG09KMCDN	ASYG12KMCDN	ASYG14KMCDN
Heating	POWERFUL	1,310	1,340	1,400
	HIGH	1,240	1,270	1,330
	MED+	1,120	1,130	1,160
	MED	1,050	1,070	1,100
	LOW	900	910	910
	QUIET	610	610	670
	Cool air prevention	580	580	580
Cooling/Fan	S-LOW	470	470	470
	POWERFUL	1,200	1,220	1,320
	HIGH	1,130	1,150	1,250
	MED	940	970	1,020
	LOW	780	810	810
	QUIET	580	580	580
	Soft quiet	510*1	510*1	510*1
S-LOW	470*2	470*2	470*2	
Dry		X zone: 580 J zone: 580	X zone: 580 J zone: 580	X zone: 580 J zone: 580

\*1: Fan mode only

\*2: Cooling mode only

##### ■ Fan operation

Airflow can be switched in 5 steps such as AUTO, QUIET, LOW, MED, HIGH while indoor unit fan only runs.

When fan mode is set at AUTO, it operates on MED fan speed.

##### ■ Cooling operation

Switch the airflow AUTO, and indoor fan motor will run according to room temperature, as below.

On the other hand, if switched in HIGH—QUIET, indoor motor will run at a constant airflow of COOL operation modes QUIET, LOW, MED, HIGH as shown in “Fan speed” above.

Airflow change over (Cooling: Auto)

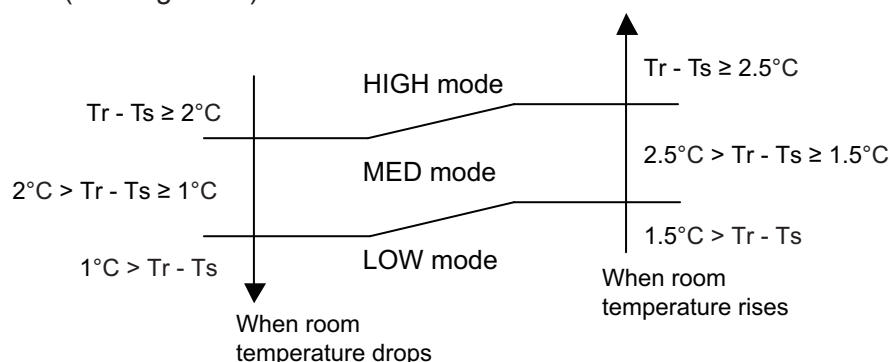

## ■ Dry operation

During dry operation, fan speed setting can not be changed as shown in “Fan speed” above.

## ■ Heating operation

Switch the airflow AUTO, and the indoor fan motor will run according to a room temperature, as below.

On the other hand, if switched in HIGH—QUIET, the indoor motor will run at a constant airflow of HEAT operation modes QUIET, LOW, MED, HIGH as shown in “Fan speed” above.

Airflow change over (Heating: Auto)

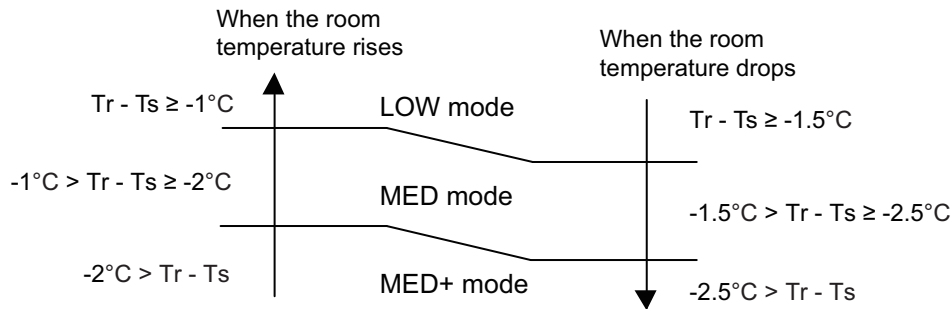

## ■ Cool air prevention control (heating mode)

The maximum value of the indoor fan speed is set as shown below, based on the detected temperature by the indoor heat exchanger sensor on heating mode.

### • Normal operation

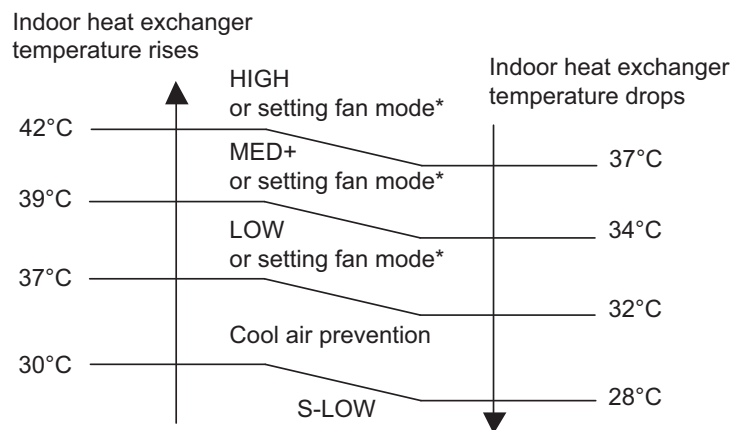

\*: Lower speed is selected.

7 minutes later:

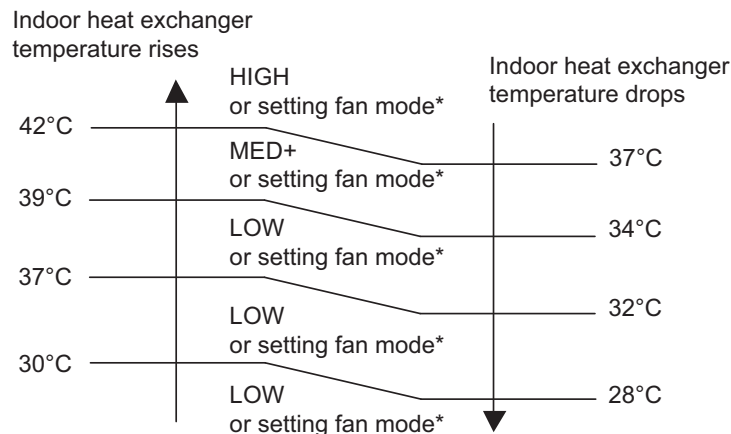

\*: Lower speed is selected.

• **Powerful operation**

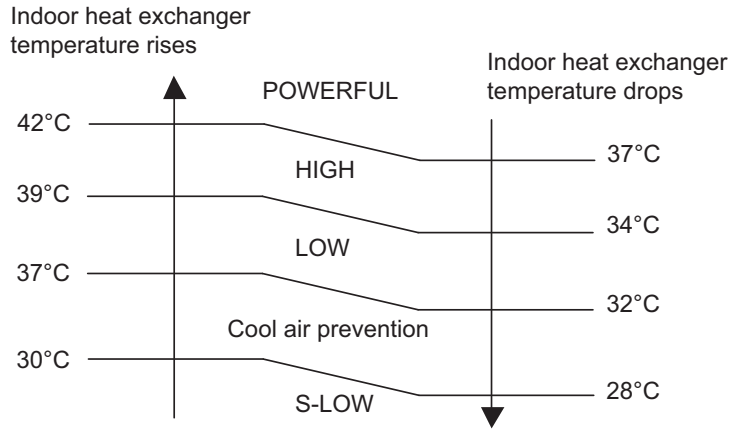

7 minutes later:

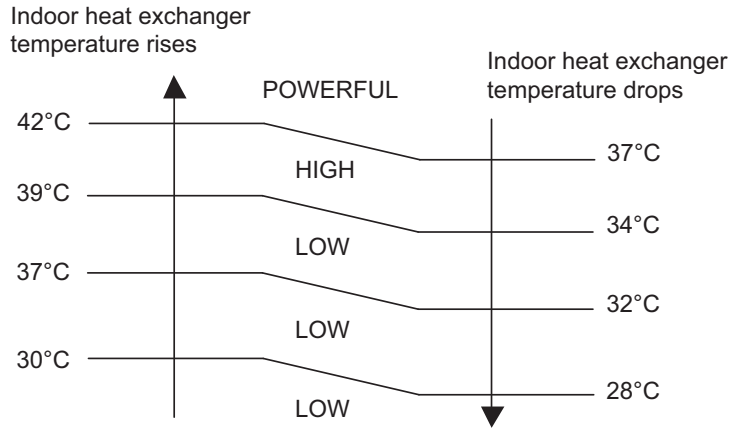

• **10 °C HEAT operation**

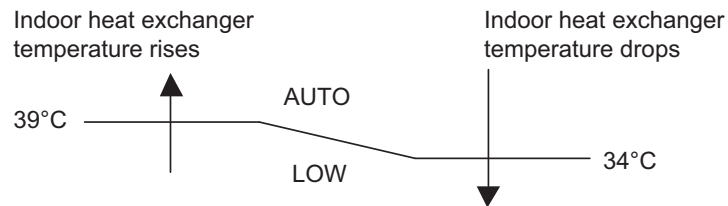

■ **Moisture return prevention control (cooling and dry mode)**

Switch the airflow AUTO at cooling mode, and the indoor fan motor will run as shown below.

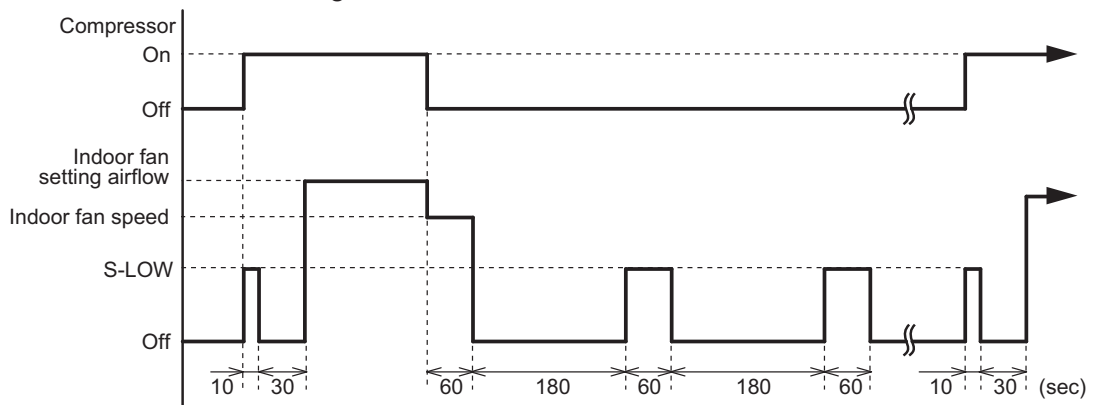



## 3-2. Outdoor fan control

### ■ Outdoor fan motor

This outdoor unit has a DC fan motor. (Control method is different between AC and DC motors.)

### ■ Fan speed

#### ● Model: AOYG09KMCDN

Fan speed is defined by outdoor temperature and compressor frequency.

##### • Outside air temperature zone selection

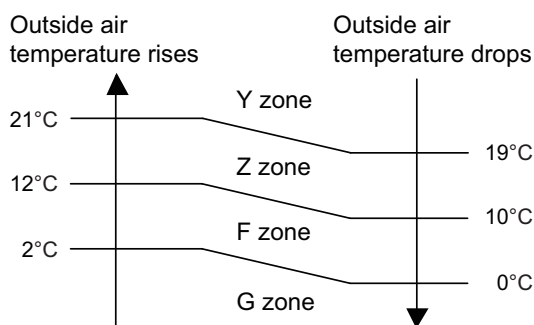

Unit: rpm

Fan step	Cooling	Heating	Dry	Cooling or dry at low outdoor temp.		
	Y zone		Y zone	Z zone	F zone	G zone
S-HIGH2	—	1,120	—	—	—	—
S-HIGH1	990	1,120	—	—	—	—
HIGH	990	870	—	—	—	—
10	—	870	—	—	—	—
9	990	870	990	630	300	280
8	920	870	920	630	300	280
7	920	870	920	630	270	220
6	920	710	920	630	270	220
5	920	660	920	610	270	210
4	810	660	810	450	240	210
3	670	500	670	310	220	200
2	570	500	570	200	220	200
1	520	500	520	200	200	200

**NOTE:** After defrost control on the heating mode, the fan speed is kept higher regardless of the compressor frequency.

Fan speed after defrost control: 1,120 rpm

● **Model: AOYG12KMCDN**

Fan speed is defined by outdoor temperature and compressor frequency.

• **Outside air temperature zone selection**

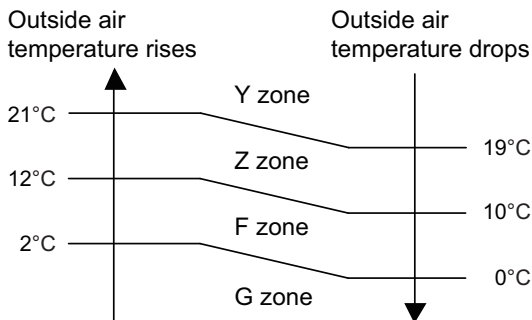

Unit: rpm

Fan step	Cooling	Heating	Dry	Cooling or dry at low outdoor temp.		
	Y zone		Y zone	Z zone	F zone	G zone
S-HIGH2	—	1,100	—	—	—	—
S-HIGH1	1,050	1,100	—	—	—	—
HIGH	1,050	870	—	—	—	—
10	—	870	—	—	—	—
9	1,050	870	1,050	850	320	270
8	1,050	850	1,050	850	320	270
7	940	680	940	770	270	270
6	890	570	890	630	230	210
5	770	500	770	440	200	180
4	630	470	630	320	200	180
3	510	420	510	320	200	180
2	400	420	400	320	200	180
1	400	420	400	320	200	180

**NOTE:** After defrost control on the heating mode, the fan speed is kept higher regardless of the compressor frequency.

Fan speed after defrost control: 1,100 rpm

CONTROL AND FUNCTIONS

CONTROL AND FUNCTIONS

## ● Model: AOYG14KMCDN

Fan speed is defined by outdoor temperature and compressor frequency.

### • Outside air temperature zone selection

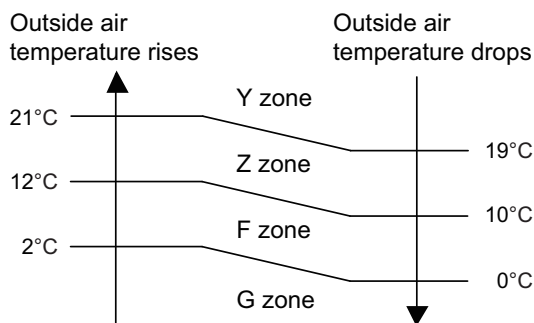

Unit: rpm

Fan step	Cooling	Heating	Dry	Cooling or dry at low outdoor temp.		
	Y zone		Y zone	Z zone	F zone	G zone
S-HIGH2	—	1,200	—	—	—	—
S-HIGH1	1,180	1,200	—	—	—	—
HIGH	1,180	1,200	—	—	—	—
10	—	1,170	—	—	—	—
9	1,180	1,170	1,180	1,180	1,180	1,180
8	1,140	1,000	1,140	600	310	220
7	900	860	900	600	310	220
6	800	750	800	450	260	200
5	690	700	690	320	230	180
4	610	610	610	320	230	180
3	550	570	550	320	230	180
2	450	510	450	320	230	180
1	400	470	400	320	230	180

**NOTE:** After defrost control on the heating mode, the fan speed is kept higher regardless of the compressor frequency.

Fan speed after defrost control: 1,200 rpm

## 4. Louver control

### 4-1. Horizontal louver control

Each time the button is pressed, the airflow direction range will change as below:

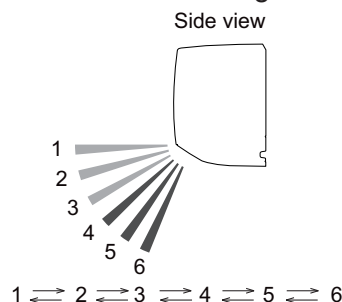

- Remote controller display is not changed.
- Up/down airflow direction is set automatically as shown, in accordance with the type of operation selected.

Cooling / Dry mode : Horizontal flow 1

Heating mode : Downward flow 6

- During AUTO operation, for the first a few minutes after beginning operation, airflow will be horizontal 1; the air direction cannot be adjusted during this period. The airflow direction setting will temporarily become 1 when the temperature of the airflow is low at the start of the Heating mode.
- After beginning of AUTO/HEAT mode operated and automatic defrosting operation, the airflow will be horizontal 1. However, the airflow direction cannot be adjusted at beginning AUTO operation mode.

### 4-2. Adjust the horizontal louver

Move the horizontal louvers to adjust airflow direction you prefer.

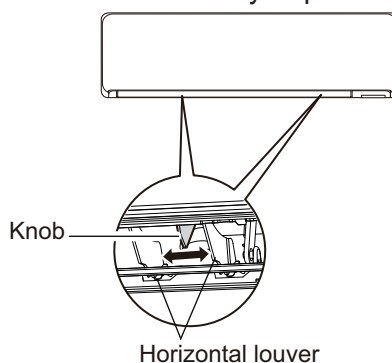

## 4-3. Swing operation

- To select up/down airflow swing operation  
When the swing signal is received, the horizontal louver starts to swing.
  - Swinging range
    - Cooling mode/dry mode/fan mode (1 to 3): 1 ↔ 4
    - Heating mode/fan mode (4 to 6): 3 ↔ 6
  - When the indoor fan is S-LOW or stop mode, the swing operation is interrupted and it stops at either upper end or bottom end.
  
- To select left/right airflow swing operation  
No function

## 5. Timer operation control

### 5-1. Wireless remote control

On/Off timer	Program timer	Sleep timer	Weekly timer
○	○	○	○

#### ■ On/Off timer

- Off timer: When the clock reaches the set timer, the air conditioner will be turned off.

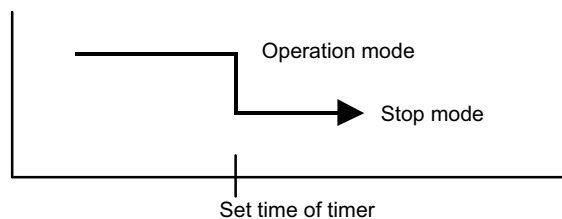

- On timer: When the clock reaches the set timer, the air conditioner will be turned on.

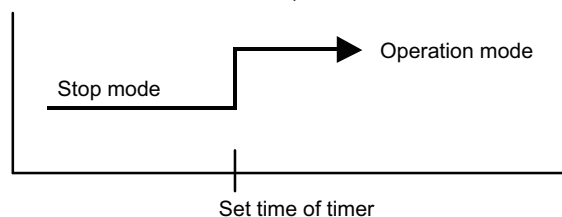

#### ■ Program timer

- The program timer allows the off timer and the on timer to be used in combination one time.

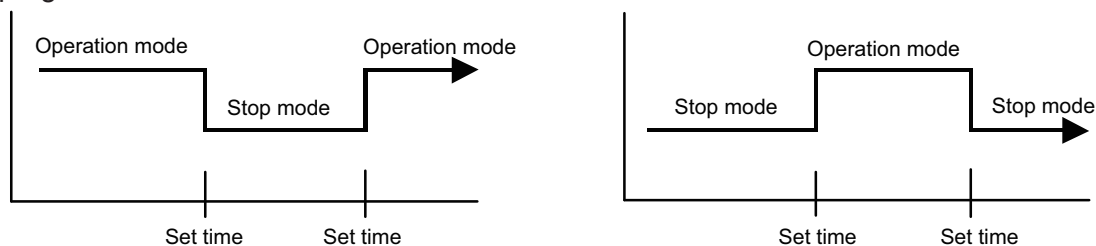

- Operation will start from the timer setting (either off timer and on timer) whichever is closest to the clock current timer setting. The order of operations is indicated by the allow in the remote controller screen.
- Sleep timer operation cannot be combined with on timer operation.

## ■ Sleep timer

If the sleep timer is set, the room temperature is monitored and the operation is stopped automatically. If the operation mode or the set temperature is change after the sleep timer is set, the operation is continued according to the changed setting of the sleep timer from that time on.

- In the cooling operation mode

When the sleep timer is set, the setting temperature is increased 1°C. It increases the setting temperature another 1°C after 1 hour. After that, the setting temperature is not changed and the operation is stopped at the setting time.

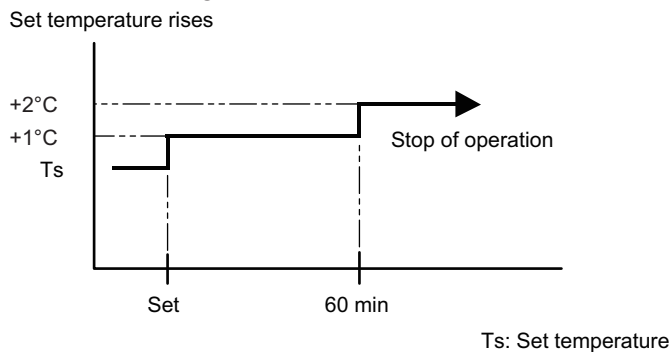

- In the heating operation mode

When the sleep timer is set, the setting temperature is decreased 1°C. It decreases the setting temperature another 1°C every 30 minutes. Upon lowering 4°C, the setting temperature is not changed and the operation is stopped at the setting time.

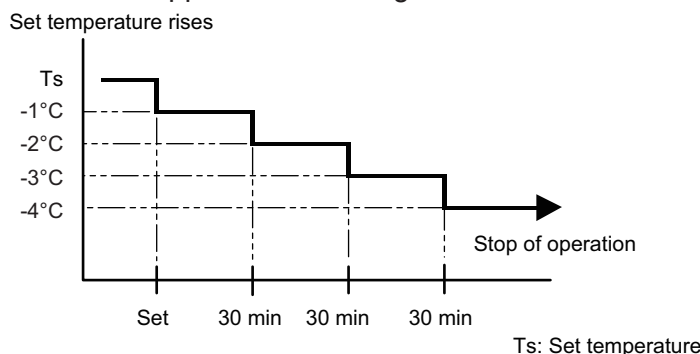

## ■ Weekly timer

On and off timer can be combined, and up to 4 reservations per day and 28 reservations per week. Before setting the program, set the week and time of the air conditioner at first. If the week and time are not set, the weekly timer will not operate correctly at the setting time.

## 5-2. Wired remote control

On/Off timer	Program timer	Sleep timer	Weekly timer	Temperature Setback Timer
○	○	○	○	○

### ■ On/Off timer

- Off timer: When the clock reaches the set timer, the air conditioner will be turned off.

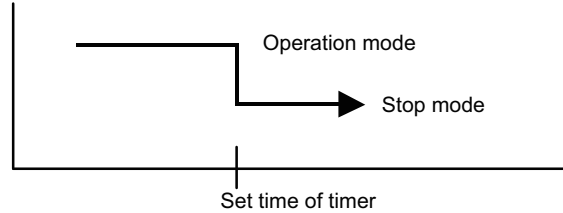

- On timer: When the clock reaches the set timer, the air conditioner will be turned on.

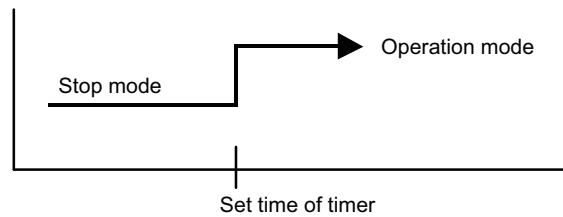

### ■ Program timer

- The program timer allows the off timer and the on timer to be used in combination one time.

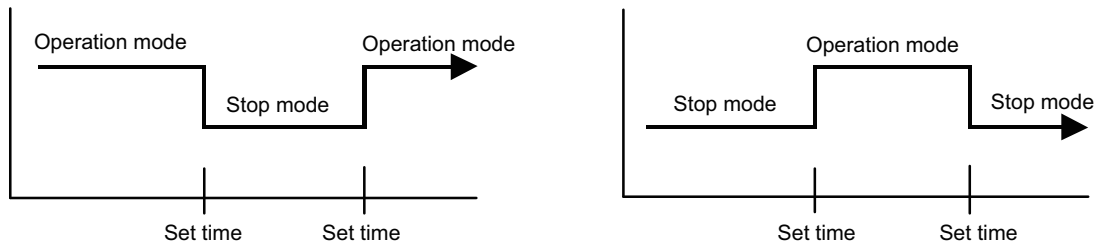

- Operation will start from the timer setting (either off timer and on timer) whichever is closest to the clock current timer setting. The order of operations is indicated by the allow in the remote controller screen.
- Sleep timer operation cannot be combined with on timer operation.



## ■ Sleep timer

If the sleep timer is set, the room temperature is monitored and the operation is stopped automatically. If the operation mode or the set temperature is change after the sleep timer is set, the operation is continued according to the changed setting of the sleep timer from that time on.

- In the cooling operation mode

When the sleep timer is set, the setting temperature is increased 1°C. It increases the setting temperature another 1°C after 1 hour. After that, the setting temperature is not changed and the operation is stopped at the setting time.

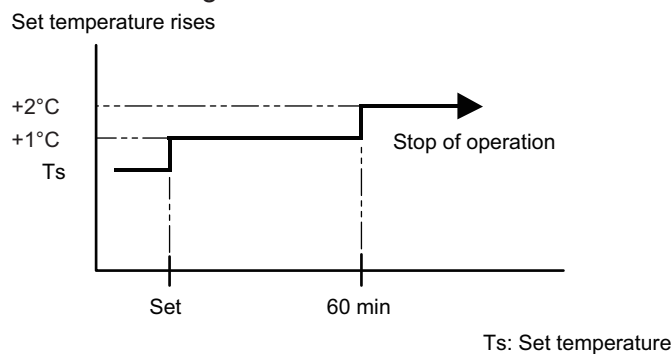

- In the heating operation mode

When the sleep timer is set, the setting temperature is decreased 1°C. It decreases the setting temperature another 1°C every 30 minutes. Upon lowering 4°C, the setting temperature is not changed and the operation is stopped at the setting time.

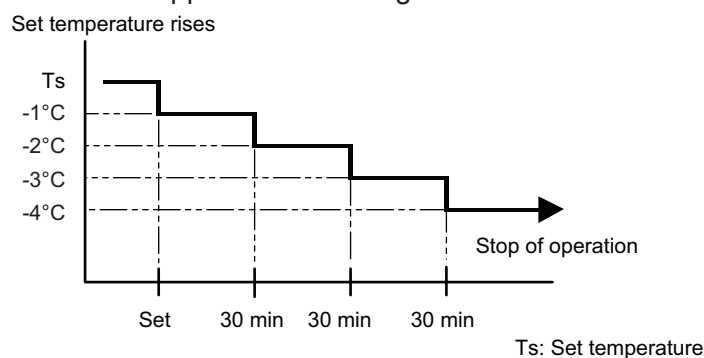

## ■ Weekly timer

On and off timer can be combined, and up to 4 reservations per day and 28 reservations per week. Before setting the program, set the week and time of the air conditioner at first. If the week and time are not set, the weekly timer will not operate correctly at the setting time.

## ■ Temperature Setback Timer

- The temperature setback timer only changes the set temperature for 7 days, it cannot be used to start or stop air conditioner operation.
- The temperature setback timer can be set to operate up to two times per day but only one temperature setting can be used.
- During COOLING/DRY mode, the air conditioner will operate at a minimum of 18°C even if the SET BACK temperature is set to 17°C or lower.

Case of Temperature Setback Timer on the Cooling operation. (Setting temperature :22°C, SET BACK temperature :26°C)

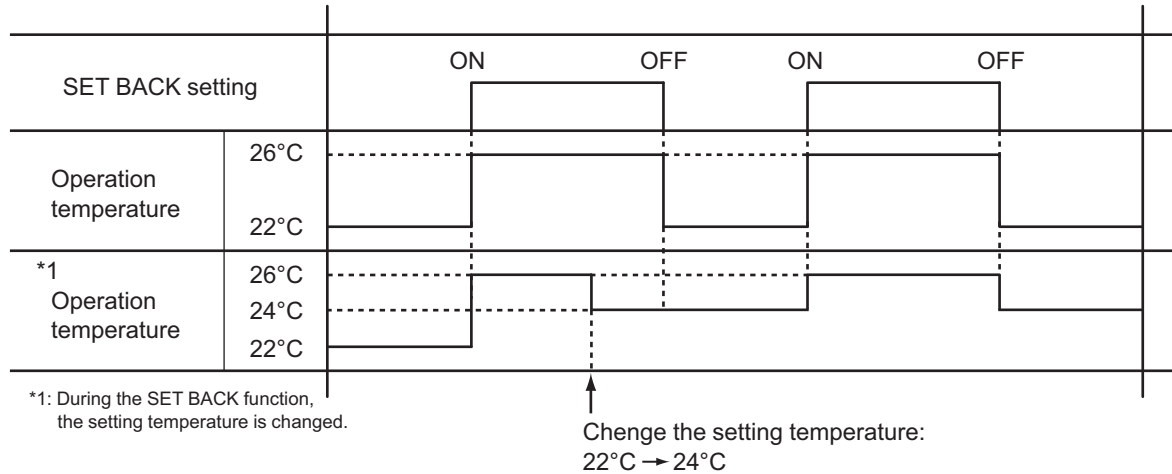

## 6. Defrost operation control

Tn: Outdoor unit heat exchanger temperature

Ta: Outdoor temperature

Tn10: Temperature at 10 minutes after compressor start

Tnb: Temperature before 5 minutes

### • Triggering condition

The defrost operation starts when outdoor unit heat exchanger temperature sensor detects the temperature lower than the values shown below.

#### – 1st time defrosting after starting operation

Compressor integrating operation time	Less than 17 min.	17 to 57 min.	More than 57 min.
Condition	Does not operate	$T_n \leq -9^\circ\text{C}$ and $T_n - T_a \geq 5$ deg	$T_n \leq -5^\circ\text{C}$

#### – 2nd time and after

Compressor integrating operation time	Less than 40 min.	More than 40 min.	
Condition	Does not operate	$T_n - T_{n10} < -5$ deg ( $T_n \leq -6^\circ\text{C}$ ) $T_n - T_{nb} < -2$ deg ( $T_n \leq -6^\circ\text{C}$ ) $T_n \leq -17^\circ\text{C}$ ( $T_a \geq -10^\circ\text{C}$ ) $T_n \leq T_a - 7^\circ\text{C}$ or $T_n \leq -30^\circ\text{C}$ ( $T_a < -10^\circ\text{C}$ )	

#### – Integrating defrost (Constant monitoring)

Compressor integrating operation time	More than 240 min. (For long continuous operation)	More than 213 min. (For long continuous operation)	Less than 10 min.* (For intermittent operation)
Condition	$T_n \leq -3^\circ\text{C}$	$T_n \leq -5^\circ\text{C}$	Count of the compressor off: 40 times

\*: If the compressor continuous operation time is less than 10 minutes, the number of the compressor off is counted. If any defrost operated, the compressor off count is cleared.

### • Release condition

The defrost operation is released when either one of the conditions below is satisfied.

Outdoor unit heat exchanger temperature (after 1 minute or later since compressor start)	16°C or more
Compressor operation time	15 minutes

## 6-1. Defrost operation in heating operation stopped

If the outdoor unit is frosted when stopping the heating operation, it stops after performing the automatic defrosting operation.

In this time, if the indoor unit operation lamp flashes slowly (6 sec on/2 sec off), the outdoor unit allow the heat exchanger to defrost, and then stop.

### • Triggering condition

When all of the following conditions are satisfied in heating operation

- Compressor operation integrating time: 30 minutes or more
- Compressor continuous operation time: 10 minutes or more
- Outdoor unit heat exchanger temperature: -4°C or less

### • Release condition

The defrost operation is released when either one of the conditions below is satisfied.

Outdoor unit heat exchanger temperature (after 1 minute or later since compressor start)	16°C or more
Compressor operation time	15 minutes

## 7. Various control

### 7-1. Auto restart

When the power was interrupted by a power failure etc. during operation, the operation contents at that time are memorized and when the power is recovered, operation is automatically started with the memorized operation contents.

Operation contents memorized when the power is interrupted
Operation mode
Setting temperature
Fan mode setting
Timer mode and set time (set by wireless remote controller)
Airflow direction setting
Swing
ECONOMY operation
10 °C HEAT operation
Outdoor low noise operation
Remote control setting
WLAN indicator lamp setting

### 7-2. MANUAL AUTO operation

When the wireless remote controller is lost or battery power dissipated, this function will work without the remote controller.

When MANUAL AUTO button is pressed more than 3 seconds and less than 10 seconds, MANUAL AUTO operation starts as shown in the table below. To stop operation, press the MANUAL AUTO button for 3 seconds.

Operation mode	Auto changeover
Fan mode	AUTO
Timer mode	Continuous (no timer setting available)
Setting temperature	24°C
Horizontal louver setting	Standard
SWING	Off
ECONOMY	Off

## 7-3. Forced cooling operation

The outdoor unit may not operate depending on the room temperature.

When FORCED COOLING OPERATION button is pressed more than 10 seconds, forced cooling operation starts as shown in the table below.

Operation mode	Cooling
Fan mode	HIGH
Timer mode	Continuous (no timer setting available)
Setting temperature	24°C
Horizontal louver setting	Standard
Vertical louver setting	According to memory position
SWING	Off
ECONOMY	Off
Human sensor	Off

- During the forced cooling operation, it operates regardless of room temperature sensor.
- The operation indicator lamp and the timer indicator lamp blink simultaneously during the forced cooling operation.  
They blink for 1 second ON and 1 second OFF on both the operation indicator lamp and the timer indicator lamp (same as test operation).

By performing one of the following action, test operation will be canceled:

- Pressing the remote controller START/STOP button
- Pressing FORCED COOLING OPERATION button for 3 seconds
- 60 minutes passed after starting forced cooling operation

**NOTE:** When HEAT operation is selected on the remote controller during forced cooling operation, heating test run will begin in about 3 minutes.

## 7-4. 10 °C HEAT operation

10 °C HEAT operation performs as below setting when pressing 10 °C HEAT button.

Operation mode	Heating
Setting temperature	10°C
Fan mode	AUTO
LED display	Economy
Defrost operation	Operate as normal

## 7-5. ECONOMY operation

The ECONOMY operation starts by pressing ECONOMY button on the remote controller.

The ECONOMY operation is almost the same operation as below settings.

Mode	Cooling/Dry	Heating
Target temperature	Setting temperature +1°C	Setting temperature -1°C

## 7-6. POWERFUL operation

The POWERFUL operation starts by pressing POWERFUL button on the remote controller. The indoor unit and outdoor unit operate at maximum power as shown in the table below.

Rotation number of compressor		Maximum
Fan mode		POWERFUL
Vertical airflow direction louver setting	Cooling	3
	Dry	
	Heating	6

### Release condition:

- Cooling/Dry  
Room temperature  $\leq$  Setting temperature  $-0.5^{\circ}\text{C}$  or Operation time has passed 20 minutes.
- Heating  
Room temperature  $\geq$  Setting temperature  $+0.5^{\circ}\text{C}$  or Operation time has passed 20 minutes.

## 7-7. Fresh air control

The fan motor for Fresh Air is operated in synchronization with the indoor fan operation as below.

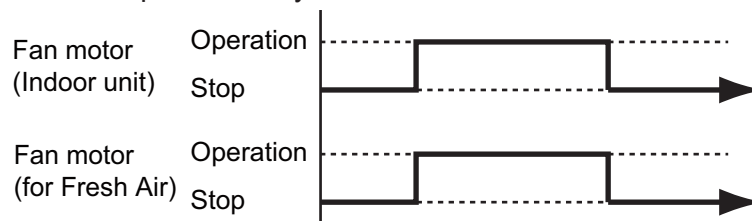

## 7-8. Compressor preheating

By preheating the compressor, warm airflow is quickly discharged when the operation is started.

- **Triggering condition**
  - 30 minutes after compressor stopped.
  - Outdoor unit heat exchanger temperature ( $T_n$ )

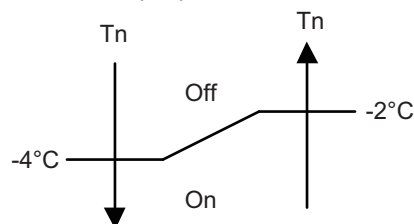

When the jumper wire (JM2) is disconnected:

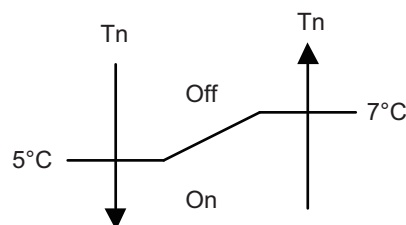

## 7-9. Electronic expansion valve control

The most proper opening of the electronic expansion valve is calculated and controlled under the present operating condition based on the table below.

Operation mode	Pulse range
Cooling/dry mode	Between 52 and 480 pulses
Heating mode	

**NOTE:** At the time of supplying the power to the outdoor unit, the initialization of the electronic expansion valve is operated (528 pulses are input to the closing direction).

## 7-10. Prevention to restart for 3 minutes (3 minutes st)

When the compressor fails to start for the number of times below, it does not enter operation status for 3 minutes.

Retry number	50
Retry set number	3

When the compressor fails to start in the retry set number above, the compressor is stopped.

## 7-11. 4-way valve control

- If heating mode is selected at the compressor start, 4-way valve is energized for heating.
- When the air conditioner is switched between cooling and heating mode, compressor is stopped, and the 4-way valve is switched when the 140 seconds passes and the compressor is started.

## 7-12. Outdoor unit low noise operation

The outdoor unit low noise operation functions by OUTDOOR UNIT LOW NOISE button on the remote controller.

This operation stops the PFC control, and changes the current value.

Operation mode	Current	
	Trigger condition	Release condition
Cooling/Dry mode	3.5 A	3.0 A
Heating mode		



## 8. Various protections

### 8-1. Discharge gas temperature over-rise prevention control

The discharge gas temperature sensor (discharge thermistor: outdoor unit side) detects the discharge gas temperature.

- When the discharge temperature becomes higher than the trigger condition, the rotation number of compressor is decreased as the table below, and it continues to decrease until the discharge temperature becomes lower than the trigger condition.
- When the discharge temperature becomes lower than the release condition, control of compressor rotation number is released.
- When the discharge temperature becomes higher than the compressor protection temperature, the compressor is stopped and the indoor unit indicator lamp starts blinking.

Trigger condition	104°C
Rotation number of compressor	-20 rps/120 seconds
Release condition	101°C
Compressor protection temperature	110°C

### 8-2. Anti-freezing control (cooling and dry mode)

The rotation number of compressor is decrease in cooling and dry mode when the indoor unit heat exchanger temperature sensor detects the temperature lower than the trigger condition.

When the indoor unit heat exchanger temperature reaches release condition, the anti-freezing control is stopped.

Trigger condition	4°C	
Release condition	Outdoor temp. $\geq 10^{\circ}\text{C}^{*1}$	7°C
	Outdoor temp. $\geq 12^{\circ}\text{C}^{*2}$	
	Outdoor temp. $< 10^{\circ}\text{C}^{*1}$	13°C
	Outdoor temp. $< 12^{\circ}\text{C}^{*2}$	

\*1: During the outdoor temperature dropping

\*2: During the outdoor temperature rising

## 8-3. Current release control

The rotation number of compressor is controlled so that the outdoor unit input current does not exceeds current limit value set according to the outdoor temperature.

The rotation number of compressor returns according to the operation mode, when the current becomes lower than the release value.

### ■ Model: AOYG09KMCDN

Operation mode	Outdoor temp. (Ta)	Trigger condition	Release condition
Cooling	$50^{\circ}\text{C} \leq \text{Ta}$	4.5 A	4.0 A
	$46^{\circ}\text{C} \leq \text{Ta} < 50^{\circ}\text{C}$	4.5 A	4.0 A
	$40^{\circ}\text{C} \leq \text{Ta} < 46^{\circ}\text{C}$	6.0 A	5.5 A
	$12^{\circ}\text{C} \leq \text{Ta} < 40^{\circ}\text{C}$	6.0 A	5.5 A
	$2^{\circ}\text{C} \leq \text{Ta} < 12^{\circ}\text{C}$	6.0 A	5.5 A
	$\text{Ta} < 2^{\circ}\text{C}$	6.0 A	5.5 A
Heating	$17^{\circ}\text{C} \leq \text{Ta}$	7.0 A	6.5 A
	$12^{\circ}\text{C} \leq \text{Ta} < 17^{\circ}\text{C}$	9.0 A	8.5 A
	$5^{\circ}\text{C} \leq \text{Ta} < 12^{\circ}\text{C}$	9.5 A	9.0 A
	$\text{Ta} < 5^{\circ}\text{C}$	9.5 A	9.0 A

### ■ Model: AOYG12KMCDN

Operation mode	Outdoor temp. (Ta)	Trigger condition	Release condition
Cooling	$50^{\circ}\text{C} \leq \text{Ta}$	4.5 A	4.0 A
	$46^{\circ}\text{C} \leq \text{Ta} < 50^{\circ}\text{C}$	4.5 A	4.0 A
	$40^{\circ}\text{C} \leq \text{Ta} < 46^{\circ}\text{C}$	6.0 A	5.5 A
	$12^{\circ}\text{C} \leq \text{Ta} < 40^{\circ}\text{C}$	6.5 A	6.0 A
	$2^{\circ}\text{C} \leq \text{Ta} < 12^{\circ}\text{C}$	6.5 A	6.0 A
	$\text{Ta} < 2^{\circ}\text{C}$	6.5 A	6.0 A
Heating	$17^{\circ}\text{C} \leq \text{Ta}$	7.0 A	6.5 A
	$12^{\circ}\text{C} \leq \text{Ta} < 17^{\circ}\text{C}$	9.0 A	8.5 A
	$5^{\circ}\text{C} \leq \text{Ta} < 12^{\circ}\text{C}$	11.0 A	10.5 A
	$\text{Ta} < 5^{\circ}\text{C}$	11.0 A	10.5 A

### ■ Model: AOYG14KMCDN

Operation mode	Outdoor temp. (Ta)	Trigger condition	Release condition
Cooling	$50^{\circ}\text{C} \leq \text{Ta}$	7.0 A	6.5 A
	$46^{\circ}\text{C} \leq \text{Ta} < 50^{\circ}\text{C}$	7.0 A	6.5 A
	$40^{\circ}\text{C} \leq \text{Ta} < 46^{\circ}\text{C}$	8.0 A	7.5 A
	$12^{\circ}\text{C} \leq \text{Ta} < 40^{\circ}\text{C}$	8.0 A	7.5 A
	$2^{\circ}\text{C} \leq \text{Ta} < 12^{\circ}\text{C}$	8.0 A	7.5 A
	$\text{Ta} < 2^{\circ}\text{C}$	8.0 A	7.5 A
Heating	$17^{\circ}\text{C} \leq \text{Ta}$	10.5 A	10.0 A
	$12^{\circ}\text{C} \leq \text{Ta} < 17^{\circ}\text{C}$	13.0 A	12.5 A
	$5^{\circ}\text{C} \leq \text{Ta} < 12^{\circ}\text{C}$	15.0 A	14.5 A
	$\text{Ta} < 5^{\circ}\text{C}$	15.5 A	15.0 A

## 8-4. Cooling pressure over-rise protection

When the outdoor unit heat exchanger temperature reaches trigger condition below, the compressor is stopped and trouble display is performed.

Trigger condition	65°C
-------------------	------

## 8-5. Compressor temperature protection

When the compressor temperature sensor detects higher than the trigger condition below, the compressor is stopped. When the compressor temperature sensor detects the release condition, the protection is released.

Trigger condition	108°C
Release condition	80°C (3 minutes after compressor stop)

## 8-6. High pressure protection

Trigger condition	Pressure switch: Off (Open: Higher than 4.2 MPa) Compressor stop
Release condition	Pressure switch: On (Close: Lower than 3.2 MPa) (3 minutes after compressor stop) Compressor restart

## 8-7. Low outdoor temperature protection

When the outdoor temperature sensor detects lower than the trigger condition below, the compressor is stopped.

Operation mode	Cooling/Dry
Trigger condition	-15°C
Release condition	-10°C

## 8-8. High temperature and high pressure release control

The compressor is controlled as follows.

### ■ Models: AOYG09KMCDN, AOYG12KMCDN, and AOYG14KMCDN

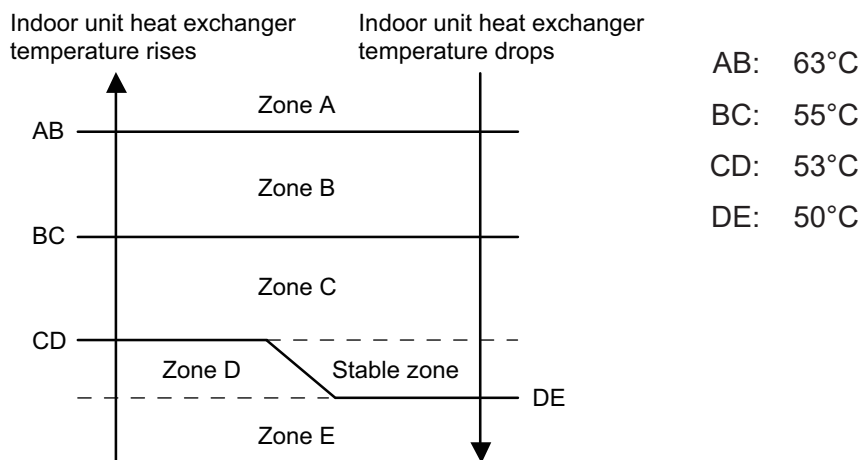

Zone	Operation	
Zone A	Compressor is stopped.	
Zone B	The rotation number of compressor is decreased.	-25 rps/120 sec.
Zone C		-3 rps/60 sec.
Zone D	The protection is released and the operation is returned to normal mode.	
Zone E		

## **5. FILED WORKING**

# CONTENTS

## 5. FILED WORKING

<b>1. Function settings</b> .....	<b>05-1</b>
1-1. Function settings by using remote controller .....	05-1
1-2. Custom code setting for wireless remote controller .....	05-8

# 1. Function settings

To adjust the functions of this product according to the installation environment, various types of function settings are available.

**NOTE:** Incorrect settings can cause a product malfunction.

## 1-1. Function settings by using remote controller

Some function settings can be changed on the remote controller. After confirming the setting procedure and the content of each function setting, select appropriate functions for your installation environment.

### ■ Setting procedure by using wireless remote controller

The function number and the associated setting value are displayed on the LCD of the remote controller. Follow the instructions written in the local setup procedure supplied with the remote controller, and select appropriate setting according to the installation environment.

**Before connecting the power supply of the indoor unit, reconfirm following items:**

- Cover for the electrical enclosure on the outdoor unit is in place.
- There is no wiring mistake.
- Piping air tightness test and vacuuming have been performed firmly.
- All the necessary wiring work for outdoor unit has been finished.

After reconfirming the items listed above, connect the power supply of the indoor unit.

#### NOTES:

- Settings will not be changed if invalid numbers or setting values are selected.
- When optional wired remote controller is used, refer to the installation manual enclosed with the remote controller.

#### Entering function setting mode:

While pressing the POWERFUL button and TEMP. (^) button simultaneously, press the RESET button to enter the function setting mode.

#### Selecting the function number and setting value:

1. Press the TEMP. (^) (v) buttons to select the function number. To switch between the left and right digits, press the 10 °C HEAT button.
2. Press the POWERFUL button to proceed to value setting. To return the function number selection, press the POWERFUL button again.
3. Press the TEMP. (^) (v) buttons to select the setting value. To switch between the left and right digits, press the 10 °C HEAT button.
4. Press the MODE button once. Confirm that you hear the beep sound.
5. Press the START/STOP button to fix the function setting. Confirm that you hear the beep sound.
6. Press the RESET button to end the function setting mode.
7. After completing the function setting, be sure to disconnect the power supply and then reconnect it.



#### ⚠ CAUTION

After disconnecting the power supply, wait 30 seconds or more before reconnecting it. The function setting will not become active unless the power supply is disconnected and then reconnected.

**NOTES:**

- The air conditioner custom code is set to  $\overline{H}$  prior to shipment.
- If you do not know the air conditioner custom code setting, try each of the custom codes ( $\overline{H} \rightarrow \overline{b}$   
 $\rightarrow \overline{c} \rightarrow \overline{d}$ ) until you find the code that operates the air conditioner.



## ■ Contents of function setting

Each function setting listed in this section is adjustable in accordance with the installation environment.

**NOTE:** Setting will not be changed if invalid numbers or setting values are selected.

### ● Function setting list

	Function no.	Functions
1)	00	Remote controller address setting
2)	11	Filter sign
3)	30/31	Room temperature control for indoor unit sensor
4)	35/36	Room temperature control for wired remote controller sensor
5)	40	Auto restart
6)	42	Room temperature sensor switching
7)	43	Cold air prevention
8)	44	Remote controller custom code
9)	46	External input control
10)	48	Room temperature sensor switching (Aux.)
11)	49	Indoor unit fan control for energy saving for cooling

#### 1) Remote controller address setting

**NOTE:** This setting is configurable only by wireless remote controller, but not configurable by Polar 3-wired remote controller.

Multiple indoor units can be operated by using one wired remote controller.

Set the unit number of each indoor unit.

Function number	Setting value	Setting description	Factory setting
00	00	Unit no. 0	◆
	01	Unit no. 1	
	02	Unit no. 2	
	03	Unit no. 3	
	04	Unit no. 4	
	05	Unit no. 5	
	06	Unit no. 6	
	07	Unit no. 7	
	08	Unit no. 8	
	09	Unit no. 9	
	10	Unit no. 10	
	11	Unit no. 11	
	12	Unit no. 12	
	13	Unit no. 13	
	14	Unit no. 14	
15	Unit no. 15		

**NOTE:** When different type of indoor units (such as wall mounted type and cassette type, cassette type and duct type, or other combinations) are connected using group control system, some functions may no longer be available.

## 2) Filter sign

Select appropriate intervals for displaying the filter sign on the indoor unit according to the estimated amount of dust in the air of the room.

If the indication is not required, select "No indication" (03).

Function number	Setting value	Setting description	Factory setting
11	00	Standard (400 hours)	
	01	Long interval (1,000 hours)	
	02	Short interval (200 hours)	
	03	No indication	◆

## 3) Room temperature control for indoor unit sensor

Depending on the installed environment, correction of the room temperature sensor may be required. Select the appropriate control setting according to the installed environment.

The temperature of the room temperature sensor is corrected as follows:

Corrected temp. = Temp. of the room temp. sensor - Correction temp. value

Example of correction:

When the temperature of the room temp. sensor is 26°C and the setting value is "03" (-1.0°C), corrected temp. will be 27°C (26°C - [-1.0°C]).

The temperature correction values show the difference from the Standard setting "00" (manufacturer's recommended value).

Function number		Setting value	Setting description	Factory setting	
30 (For cooling)	31 (For heating)	00	Standard setting	◆	
		01	No correction 0.0 °C		
		02	-0.5 °C	More cooling Less heating	
		03	-1.0 °C		
		04	-1.5 °C		
		05	-2.0 °C		
		06	-2.5 °C		
		07	-3.0 °C		
		08	-3.5 °C		
		09	-4.0 °C		
		10	+0.5 °C	Less cooling More heating	
		11	+1.0 °C		
		12	+1.5 °C		
		13	+2.0 °C		
		14	+2.5 °C		
		15	+3.0 °C		
		16	+3.5 °C		
17	+4.0 °C				

#### 4) Room temperature control for wired remote controller sensor

Depending on the installed environment, correction of the wire remote temperature sensor may be required. Select the appropriate control setting according to the installed environment.

To change this setting, set Function 42 to Both "01".

Ensure that the Thermo Sensor icon is displayed on the remote controller screen.

Function number		Setting value	Setting description	Factory setting	
35 (For cooling)	36 (For heating)	00	Standard setting	◆	
		01	No correction 0.0°C		
		02	-0.5 °C	More cooling Less heating	
		03	-1.0 °C		
		04	-1.5 °C		
		05	-2.0 °C		
		06	-2.5 °C		
		07	-3.0 °C		
		08	-3.5 °C		
		09	-4.0 °C		
		10	+0.5 °C	Less cooling More heating	
		11	+1.0 °C		
		12	+1.5 °C		
		13	+2.0 °C		
		14	+2.5 °C		
		15	+3.0 °C		
		16	+3.5 °C		
17	+4.0 °C				

#### 5) Auto restart

Enables or disables automatic restart after a power interruption.

Function number	Setting value	Setting description	Factory setting
40	00	Enable	◆
	01	Disable	

**NOTE:** Auto restart is an emergency function such as for power outage etc. Do not attempt to use this function in normal operation. Be sure to operate the unit by remote controller or external device.

#### 6) Room temperature sensor switching

(Only for wired remote controller)

When using the wired remote controller temperature sensor, change the setting to "Both" (01).

Function number	Setting value	Setting description	Factory setting
42	00	Indoor unit	◆
	01	Both	

00: Sensor on the indoor unit is active.

01: Sensors on both indoor unit and wired remote controller are active.

**NOTE:** Remote controller sensor must be turned on by using the remote controller.

## 7) Cold air prevention

This setting is to disable the cold air prevention function during heating operation. When disabled, the fan setting will always follow the setting on the remote controller. (Excluding defrost mode)

Function number	Setting value	Setting description	Factory setting
43	00	Enable	◆
	01	Disable	

**NOTE:** The customer may feel the cold air at the time heating operation starts, and at the time outdoor unit recovers from defrosting operation if the "Cold air prevention control" is disabled by the local function setting.

## 8) Remote controller custom code

(Only for wireless remote controller)

The indoor unit custom code can be changed. Select the appropriate custom code.

Function number	Setting value	Setting description	Factory setting
44	00	A	◆
	01	B	
	02	C	
	03	D	

## 9) External input control

"Operation/Stop" mode or "Forced stop" mode can be selected.

Function number	Setting value	Setting description	Factory setting
46	00	Operation/Stop mode 1	◆
	01	(Setting prohibited)	
	02	Forced stop mode	
	03	Operation/Stop mode 2	

**NOTE:** If this function is necessary, the rotary switch on the External input and output PCB should be set to 1.

## 10) Room temperature sensor switching (Aux.)

To use the temperature sensor on the wired remote controller only, change the setting to "Wired remote controller" (01).

This function will only work if the function setting 42 is set at "Both" (01).

When the setting value is set to "Both" (00), more suitable control of the room temperature is possible by setting function setting 30 and 31 too.

Function number	Setting value	Setting description	Factory setting
48	00	Both	◆
	01	Wired remote controller	

**11) Indoor unit fan control for energy saving for cooling**

Enables or disables the power-saving function by controlling the indoor unit fan rotation when the outdoor unit is stopped during cooling operation.

Function number	Setting value	Setting description	Factory setting
49	00	Disable	
	01	Enable	
	02	Remote controller	◆

00: When the outdoor unit is stopped, the indoor unit fan operates continuously following the setting on the remote controller.

01: When the outdoor unit is stopped, the indoor unit fan operates intermittently at a very low speed.

02: Enable or disable this function by remote controller setting.

**NOTE:** Set to "00" or "01" when connecting a remote controller that cannot set the Fan control for energy saving function or connecting a network converter. To confirm if the remote controller has this setting, refer to the operating manual of each remote controller.

## 1-2. Custom code setting for wireless remote controller

To interconnect the air conditioner and the wireless remote controller, assignment of the custom code for the wireless remote controller is required.

**NOTE:** Air conditioner cannot receive a signal if the air conditioner has not been set for the custom code.

When 2 or more air conditioners are installed in a room, and the remote controller is operating an air conditioner other than the one you wish to set, change the custom code of the remote controller to operate only the air conditioner you wish to set. (4 selections possible.)

Confirm the setting of the remote controller custom code and the function setting. If these do not match, the remote controller cannot be used to operate for the air conditioner.

1. Press the START/STOP button until only the clock is displayed on the remote controller display.
2. Press the MODE button for at least 5 seconds to display the current custom code. (Initially set to  $\text{H}$ .)
3. Press the TEMP. ( $\wedge$ ) ( $\vee$ ) buttons to change the custom code between  $\text{H} \rightarrow \text{b} \rightarrow \text{c} \rightarrow \text{d}$ . Match the code on the display to the air conditioner custom code. (Initially set to  $\text{H}$ .)
4. Press the MODE button again to return to the clock display. The custom code will be changed.

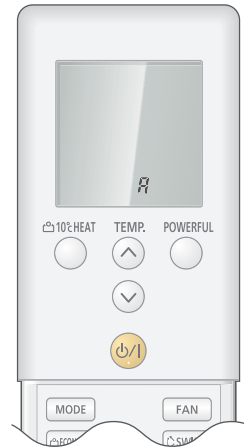

### NOTES:

- If no button is pressed within 30 seconds after the custom code is displayed, the system returns to the original clock indicator. In this case, start again from step 1.
- The air conditioner custom code is set to  $\text{H}$  prior to shipment. To change the custom code, contact your retailer.
- If you do not know the assigned code for the air conditioner, try each of the custom code ( $\text{H} \rightarrow \text{b} \rightarrow \text{c} \rightarrow \text{d}$ ) until you find the code which operates the air conditioner.