



**BITZER Output data**

Created on : 01.01.2020 18:10:09



## Table of content

Project survey.....	3
Selection: Semi-hermetic Reciprocating Compressors.....	4
Technical Data: 2GES-2Y.....	5
Information: Semi-hermetic Reciprocating Compressors.....	6
Selection: Horizontal receivers.....	8
Information: Liquid receiver.....	9



## Project survey

### **Selected compressors**

Semi-hermetic Reciprocating Compressors

1x 2GES-2Y

### **Chosen accessory**

[Horizontal receivers](#)



## Selection: Semi-hermetic Reciprocating Compressors

### Input Values

Compressor model Mode	2GES-2Y Refrigeration and Air conditioning	Suction gas temperature Operating mode	20,00 °C Auto
Refrigerant	R449A	Power supply	400V-3-50Hz
Reference temperature	Dew point temp.	Capacity control	100%
Liq. subc. (in condenser)	0 K	Useful superheat	100%

### Result

Q [W]	Cooling capacity	COP [ - ]	COP/EER
Qu* [W]	Evaporator capacity	m [kg/h]	Mass flow
P [kW]	Power input	Op.	Operating mode
I [A]	Current	th [°C]	Discharge gas temp. w/o cooling
Qc [W]	Condenser capacity		

tc	to	10°C	5°C	0°C	-5°C	-10°C	-15°C	-20°C	-25°C
30°C	Q [W]	9803	8111	6659	5415	4351	3447	2683	2041
	Qu* [W]	9803	8111	6659	5415	4351	3447	2683	2041
	P [kW]	1,42	1,48	1,49	1,46	1,40	1,30	1,18	1,05
	I [A]	3,14	3,20	3,22	3,18	3,12	3,02	2,90	2,78
	Qc [W]	11225	9592	8152	6877	5748	4749	3867	3091
	COP [ - ]	6,90	5,48	4,46	3,70	3,12	2,65	2,27	1,95
	m [kg/h]	201	164,1	133,3	107,4	85,6	67,4	52,2	39,5
	Op.	Standard	Standard	Standard	Standard	Standard	Standard	Standard	Standard
	th [°C]	54,9	63,6	72,8	82,7	93,2	104,7	117,2	131,0
	40°C	Q [W]	8472	7000	5734	4647	3718	2927	2258
Qu* [W]		8472	7000	5734	4647	3718	2927	2258	1698
P [kW]		1,83	1,81	1,75	1,66	1,54	1,40	1,24	1,07
I [A]		3,59	3,57	3,50	3,40	3,27	3,11	2,96	2,80
Qc [W]		10301	8811	7486	6306	5255	4322	3497	2772
COP [ - ]		4,63	3,87	3,27	2,80	2,42	2,10	1,82	1,58
m [kg/h]		191,2	155,7	126,1	101,2	80,3	62,7	48,1	36,0
Op.		Standard	Standard	Standard	Standard	Standard	Standard	Standard	Standard
th [°C]		68,7	77,3	86,5	96,2	106,6	117,9	130,5	0
50°C		Q [W]	7074	5828	4752	3825	3029	2350	1774
	Qu* [W]	7074	5828	4752	3825	3029	2350	1774	1290
	P [kW]	2,21	2,12	1,99	1,84	1,66	1,48	1,29	1,10
	I [A]	4,05	3,93	3,78	3,60	3,40	3,20	3,01	2,83
	Qc [W]	9287	7946	6742	5661	4693	3829	3064	2394
	COP [ - ]	3,20	2,75	2,39	2,08	1,82	1,59	1,37	1,17
	m [kg/h]	179,0	145,1	116,8	92,9	72,9	56,1	42,1	30,4
	Op.	Standard	Standard	Standard	Standard	Standard	Standard	Standard	Standard
	th [°C]	83,4	92,2	101,6	111,6	122,7	135,1	0	0

-- No calculation possible (see message in single point selection)  
 \*According to EN12900 (20°C suction gas temp., 0K liquid subcooling)

### Application Limits 100% 2GES-2

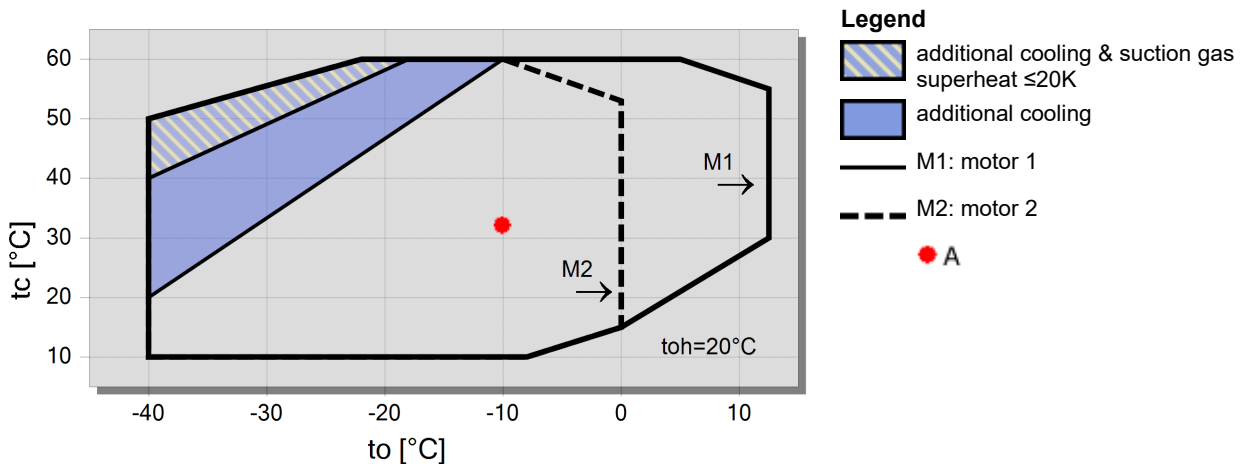



## Technical Data: 2GES-2Y

### Dimensions and Connections

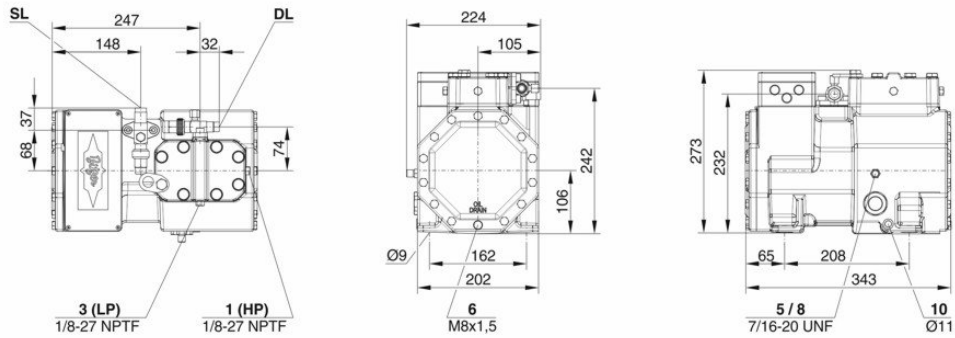

### Technical Data

#### Technical Data

Displacement (1450 RPM 50Hz)	7,58 m <sup>3</sup> /h
Displacement (1750 RPM 60Hz)	9,15 m <sup>3</sup> /h
No. of cylinder x bore x stroke	2 x 41 mm x 33 mm
Weight	45 kg
Max. pressure (LP/HP)	19 / 32bar
Connection suction line	16 mm - 5/8"
Connection discharge line	12 mm - 1/2"
Oil type R134a/R407C/R404A/R507A/R407A/R407F	BSE32(Standard)   R134a tc>70°C: BSE55 (Option)
Oil type R22 (R12/R502)	B5.2 (Option)
Oil type R1234yf/R1234ze	BSE32 (Standard)   R1234ze tc>70°C & to>0°C: BSE55 (Option)   R1234ze to>15°C: BSE85K (Option)

#### Motor data

Motor version	1
Motor voltage (more on request)	380-420V Y-3-50Hz
Max operating current	5.0 A
Starting current (Rotor locked)	22.5 A
Max. Power input	2,7 kW

#### Extent of delivery (Standard)

Motor protection	SE-B1
Enclosure class	IP66
Vibration dampers	Standard
Oil charge	1,00 dm <sup>3</sup>
Discharge shut-off valve	Standard
Suction shut-off valve	Standard

#### Available Options

Additional fan	Option
Crankcase heater	0..60 W PTC (Option)

#### Sound measurement

Sound power level (+5°C / 50°C)	64,0 dB(A) @ 50Hz
Sound power level (-10°C / 45°C)	63,0 dB(A) @ 50Hz
Sound power level (-35°C / 40°C)	63,5 dB(A) @ 50Hz
Sound pressure level @ 1m (+5°C / 50°C)	56,0 dB(A) @ 50Hz
Sound pressure level @ 1m (-10°C / 45°C)	55,0 dB(A) @ 50Hz
Sound pressure level @ 1m (-35°C / 40°C)	55,5 dB(A) @ 50Hz



## Semi-hermetic Reciprocating Compressors

**Motor 1** = e.g. 4TES-12 with 12 "HP", primary for air-conditioning (e.g. R22,R407C) and air-conditioning with R134a at high ambient temperatures.

**Motor 2** = e.g. 4TES-9 with 8 "HP", universal Motor for medium and low temperature application (e.g. R404A, R507A, R407A, R407F) and air-conditioning with R134a

**Motor 3** = e.g. 4TES-8, for medium temperature applications and R134a

For more information concerning the application range use the "Limits" button.

### Operation modes 4VES-7 to 6FE-44 and 44JE-30 to 66FE-88 with R407F/R407A/R22

CIC = liquid injection with low temperature application, suction gas cooled motor.

### ASERCOM certified performance data

The Association of European Refrigeration Component Manufacturers has implemented a procedure of certifying performance data. The high standard of these certifications is assured by:

- \* plausibility tests of the data performed by experts.
- \* regular measurements at independent institutes.

These high efforts result in the fact that only a limited number of compressors can be submitted. Due to this not all BITZER compressors are certified until now. Performance data of compressors which fulfil the strict requirements may carry the label "ASERCOM certified". In this software you will find the label at the respective compressors on the right side below the field "result" or in the print out of the performance data. All certified compressors and further information are listed on the homepage of ASERCOM.

### Condensing capacity

The condensing capacity can be calculated with or without heat rejection. This option can be set in the menu Program  Options. The heat rejection is constantly 5 % of the power consumption. The condensing capacity is to be found in the line Condensing cap. (with HR) resp. Condensing capacity.

### Data for sound emission

Data based on 50 HZ application (IP-units 60 Hz) and R404A if not declared.

Sound pressure level: values based on free field area conditions with hemispherical sound emission in 1 meter distance.

### General remarks regarding sound data

Listed sound data were measured under testing conditions in our laboratory. For this purpose the free-standing test sample is mounted on a solid foundation plate and the pipework is connected vibration-free to the largest extent possible. Suction and discharge lines are fixed in a flexible configuration, such that a transmission of vibrations to the environment can be largely excluded. In real installations considerable differences might be observed, compared to the measurements in the laboratory. The airborne sound emitted by the compressor can be reflected from surfaces of the system and this may increase the airborne sound level measured close to the compressor. Vibrations caused by the compressor are also transferred to the system by the compressor feet and piping depending on the damping ratio of the fixings. Thus, the vibrations can induce other components to such an extent that these components contribute to an increase in airborne sound emission. If required, the transfer of vibrations to the system can be minimized by suitable fixing and damping elements.

### Legend of connection positions according to "Dimensions":

- 1 High pressure connection (HP)
- 2 Connection for discharge gas temperature sensor (HP) (for 4VE(S)-6Y .. 4NE(S)-20(Y) connection for CIC sensor as alternative)
- 3 Low pressure connection (LP)
- 4 CIC system: injection nozzle (LP)
- 4b Connection for CIC sensor
- 4c Connection for CIC sensor (MP / operation with liquid subcooler)
- 5 Oil fill plug
- 6 Oil drain
- 7 Oil filter (magnetic screw)
- 8 Oil return (oil separator)
- 8\* Oil return with NH3 and insoluble oil
- 9 Connection for oil and gas equalization (parallel operation)
- 9a Connection for gas equalization (parallel operation)
- 9b Connection for oil equalization (parallel operation)
- 10 Oil heater connection
- 11 Oil pressure connection +
- 12 Oil pressure connection -
- 13 Cooling water connection
- 14 Intermediate pressure connection (MP)
- 15 Liquid injection (operation without liquid subcooler and with thermostatic expansion valve)
- 16 Connection for oil monitoring (opto-electrical oil monitoring "OLC-K1" or differential oil pressure switch "Delta-PII")



- 17 Refrigerant inlet at liquid subcooler
  - 18 Refrigerant outlet at liquid subcooler
  - 19 Clamp space
  - 20 Terminal plate
  - 21 Maintenance connection for oil valve
  - 22 Pressure relief valve to the atmosphere (discharge side)
  - 23 Pressure relief valve to the atmosphere (suction side)
  - 24 IQ MODULE
  - SL Suction gas line
  - DL Discharge gas line
- Dimensions can show tolerances according to EN ISO 13920-B.



## Selection: Horizontal receivers

### *Input Values*

Common	Yes
Auto	
Operating point	Auto

### *Operating Points*

	<b>A</b>
to [°C]	-10
tc [°C]	32

### *Result*





Selection of the receivers:

1) "Approx. according to cooling capacity":

The receiver volume is determined by the design of the unit, the operating mode and the function of the receiver (receiving the complete refrigerant charge in the receiver or only compensating capacity variations). When selected via cooling capacity, an approximate selection of the receiver is obtained. Receivers in systems with long pipelines, winter control or in very compact systems should be selected according to method 2).

2) "According to refrigerant charge in the receiver":

The calculation is made on the basis of the specified refrigerant charge. The receiver volume is determined at 20°C and at a maximum filling charge of 95% of the possible receiver content.

Compressor units equipped with receiver

The BITZER range of products comprises compressor units with horizontal receivers. In the output window of the accessories these units, which are included in the standard delivery, are marked with "mounted" in the compressor unit line. Units that can be mounted, but are not included in the Bitzer delivery program, are marked with "single parts". Units in which the compressor does not fit onto the receiver are marked with "--".