



BITZER Output data

Created on : 06.01.2020 14:38:27



Table of content

Project survey.....	3
Selection: Condensing Units.....	4
Technical Data: LH135E/4PES-15Y.....	5
Information: Condensing Units.....	6



Project survey

Selected compressors

Condensing Units

1x LH135E/4PES-15Y



Selection: Condensing Units

Input Values

Unit type	LH135E/4PES-15Y	Useful superheat	100%
Series	Standard	Operating mode	Auto
Refrigerant	R449A	Power supply	400V-3-50Hz
Reference temperature	Dew point temp.	Capacity control	100%
Suction gas temperature	20,00 °C		

Result

Q [W]	Cooling capacity	Op.	Operating mode
P [kW]	Power input	tc [°C]	Condensing SDT
I [A]	Current	dtau [K]	subcooling
m [kg/h]	Mass flow		

tamb	to	10°C	5°C	0°C	-5°C	-10°C	-15°C	-20°C	-25°C
27°C	Q [W]	50753	43472	36794	30740	25313	20505	16295	12657
	P [kW]	13,19	12,27	11,33	10,39	9,43	8,48	7,51	6,55
	I [A]	21,9	20,6	19,23	17,93	16,66	15,45	14,31	13,26
	m [kg/h]	1232	1008	821	663	531	420	327	250
	Op.	Standard	Standard	Standard	Standard	Standard	Standard	Standard	Standard
	tc [°C]	49,4	46,7	44,3	42,0	40,0	38,1	36,5	35,0
	dtau [K]	3,00	3,00	3,00	3,00	3,00	3,00	3,00	3,00
32°C	Q [W]	47325	40472	34180	28476	23366	18843	14890	11482
	P [kW]	13,85	12,86	11,85	10,82	9,77	8,72	7,67	6,62
	I [A]	22,9	21,4	19,97	18,52	17,10	15,75	14,49	13,32
	m [kg/h]	1206	984	798	643	512	403	312	236
	Op.	Standard	Standard	Standard	Standard	Standard	Standard	Standard	Standard
	tc [°C]	53,4	50,9	48,5	46,4	44,4	42,6	41,1	39,7
	dtau [K]	3,00	3,00	3,00	3,00	3,00	3,00	3,00	3,00
43°C	Q [W]	--	33855	28459	23555	19161	15279	11898	8995
	P [kW]	--	13,96	12,77	11,56	10,32	9,07	7,81	6,57
	I [A]	--	23,1	21,3	19,55	17,83	16,19	14,65	13,27
	m [kg/h]	--	928	746	595	469	364	277	205
	Op.	--	Standard	Standard	Standard	Standard	Standard	Standard	Standard
	tc [°C]	--	60,0	57,9	56,0	54,2	52,6	51,2	49,9
	dtau [K]	--	3,00	3,00	3,00	3,00	3,00	3,00	2,98

-- No calculation possible (see message in single point selection)
 Power input compressor, power input fan see "T. Data"

Application Limits 1 LH135E/4PES-15

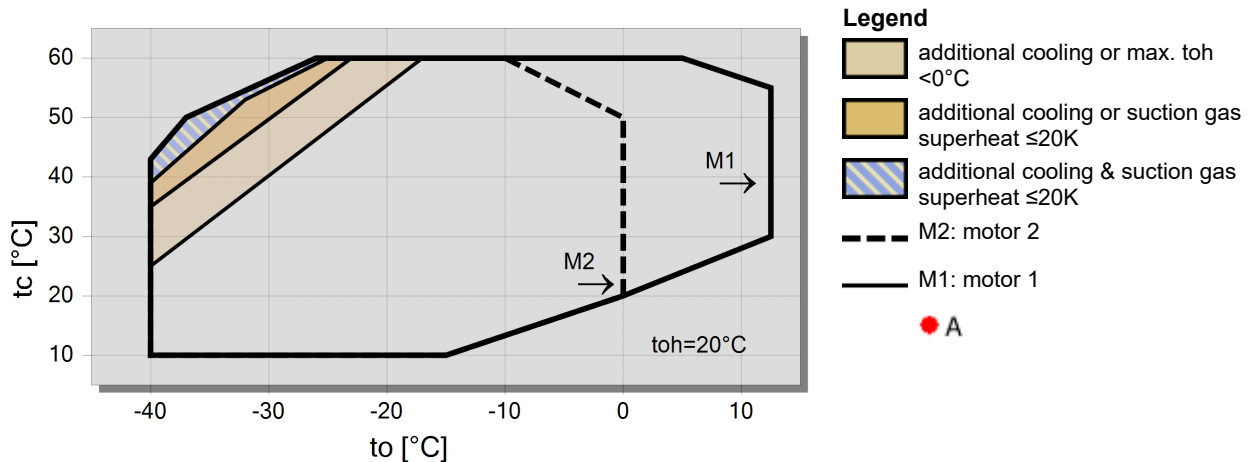



Technical Data: LH135E/4PES-15Y

Dimensions and Connections

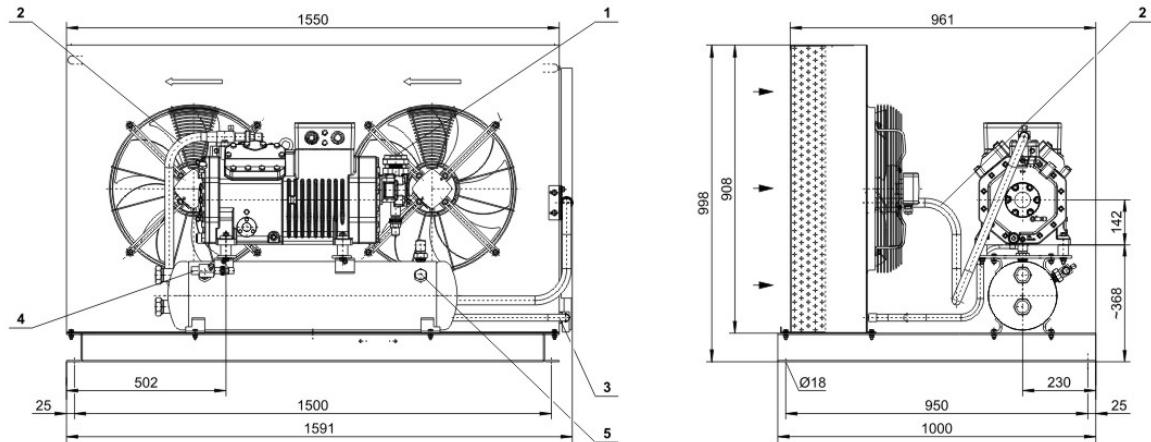

Technical Data

Technical Data

Weight	303 kg
Total width	1591 mm
Total depth	1000 mm
Total height	998 mm
Connection suction line	42 mm - 1 5/8"
Connection liquid line	22 mm - 7/8"
Fans: Number	2xEC
Voltage (50Hz, more on request)	230V-1-50Hz (Standard)
Current / Power consumption of each fan (50Hz)	1,6 A / 315 W
Air flow condenser 50Hz	10400 m ³ /h
Voltage (60Hz, more on request)	230V-1-60Hz (Standard)
Current / Power consumption of each fan (60Hz)	2,0 A / 340 W
Air flow condenser 60Hz	10400 m ³ /h
Coil Volume	4,9 dm ³
Receiver type (Standard)	F302H
Max. refrigerant charge 90% at 20°C / 68°F	
R22	32,7 kg
R134a	33,1 kg
R407C	31,3 kg
R404A/R507A	28,8 kg
R407A	31,6 kg
R407F	30,7 kg
R448A	30,1 kg
R449A	30,2 kg
R450A	32,2 kg
R513A	33,1 kg
R1234yf	30 kg
R1234ze	31,8 kg

Extent of delivery (Standard)

Discharge line	Standard
Protective charge	Standard

Available Options

Oil separator	Option
Check valve	Option
High & low pressure switch	Option
Dressed unit	Option
Weather protective housing	Option

Sound measurement

Data of compressors: see compressor program



Condensing Units

Motor 1 = e.g. LH..E/4TES-12 with 12 "HP", primary for air-conditioning (e.g. R22,R407C) and medium temperature application (e.g. R134a, R407F, R407A, R404A, R507A, R22) and air-conditioning with R134a at high ambient temperatures.

Motor 2 = e.g. LH..E/4TES-9 with 8 "HP", for medium and low temperature application (e.g. R134a, R407F, R407A, R404A, R507A, R22) and air-conditioning with R134a.

For more information concerning the application range use the "limits" button.

Operation modes for LH..E/4VES-7 to LH../6HE-28 with R22

CIC = liquid injection with low temperature application, suction gas cooled motor

Specifications for sound emission Ecostar

The data are based on 50 Hz operation with R404A.

Soundpressure: Data are valid for free field conditions according to EN13487 with a block-shaped reference area in a distance of 10m.

For further informations see technical information for sound data.

Legend of connection positions according to "Dimensions":

- 1 Suction gas valve
- 2 Discharge gas line
- 3 Condensate line
- 4 Refrigerant outlet (liquid line)
- 5 Pressure relief valve connection
- 6 Liquid injection (operation without liquid subcooler and with thermostatic expansion valve)
- 7 Refrigerant inlet at liquid subcooler
- 8 Refrigerant outlet at liquid subcooler
- 9 Suction gas line
- 10 Sight glass
- 11 Load suspension points
- 12 Plug for screwed cable gland
- 13 Cable bushing (for cables \varnothing 9-17 mm) (only ECOLITE)

Dimensions can show tolerances according to EN ISO 13920-B.